

# 736HPA High Pressure Dispense Valve

## MAINTENANCE & PARTS GUIDE

Electronic pdf files of EFD® manuals are also available at [www.efd-inc.com/manuals.html](http://www.efd-inc.com/manuals.html).

**IMPORTANT!**  
**Save this Sheet.**

**Forward to  
Maintenance or  
Tool Crib  
Supervisors**

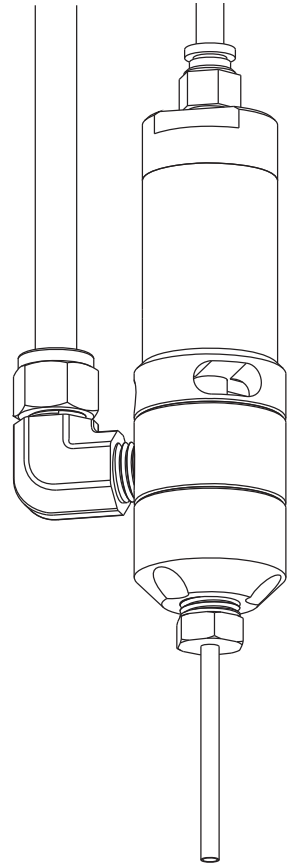

For EFD sales and service in over 30 countries,  
contact EFD or go to [www.efd-inc.com/contact](http://www.efd-inc.com/contact)

### **EFD, Inc.**

East Providence, RI USA

USA & Canada: 800-556-3484; +1-401-434-1680

[info@efd-inc.com](mailto:info@efd-inc.com)

[www.efd-inc.com](http://www.efd-inc.com)

### **EFD International Inc.**

Dunstable, Bedfordshire, UK

0800 585733 or +44 (0) 1582 666334

Ireland 00800 8272 9444

[europe@efd-inc.com](mailto:europe@efd-inc.com)

[www.efd-inc.com](http://www.efd-inc.com)

### **EFD, Inc., Asia**

China: +86 (21) 5854 2345

[china@efd-inc.com](mailto:china@efd-inc.com)

[www.efd-inc.com/cn](http://www.efd-inc.com/cn)

Singapore: +65 6796 9630 [sin-mal@efd-inc.com](mailto:sin-mal@efd-inc.com)

# Valve Disassembly and Reassembly Procedures

## To replace the lower seal:

1. Remove the three bolts from the outlet cap.
2. Remove the outlet cap.
3. Pry the seal out of the outlet cap using a small screwdriver.
4. Clean the seal cavity and then press a new seal into the cavity. Insert tapered end first, so that the O-ring faces up.
5. Inspect the fluid body O-ring and replace if necessary.
6. Reinstall the outlet cap. Tighten the three bolts to 30 to 35 inch pounds.

## To replace the upper seal:

7. Remove the three bolts from the outlet cap.
8. Remove the outlet cap and fluid body.

9. Pry the seal out of the fluid body using a small screwdriver.
10. Clean the seal cavity and then press a new seal into cavity. Insert seal with O-ring facing inside the fluid body.
11. Reinstall the outlet cap and fluid body. Tighten the three bolts to 30 to 35 inch pounds.

## To replace air cylinder seals:

12. Remove the three bolts from the outlet cap.
13. Remove the outlet cap and fluid body.
14. Unscrew the adjustable stroke air cap.
15. Remove the piston-and-spool assembly and the piston return spring.

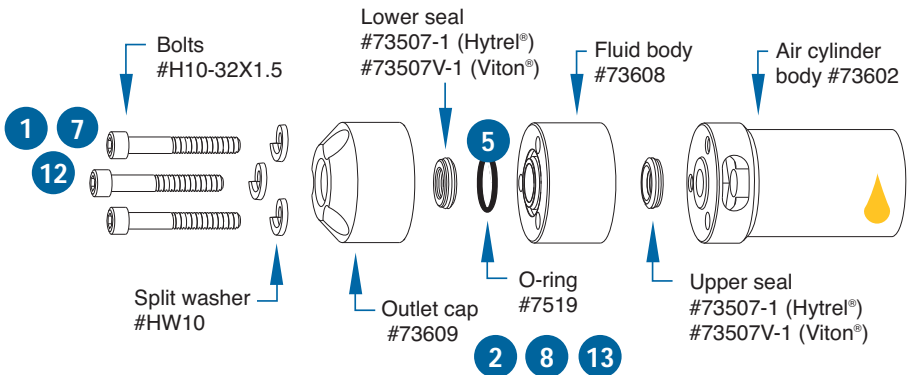

16. Replace the O-rings on the spool, piston and air cylinder body.
17. Apply Nye lubricant #865 gel to piston, spool and air cylinder wall.
18. Reinstall the piston return spring, piston and spool assembly and then the adjustable stroke air cylinder cap. Tighten the air cap between 8 to 10 foot pounds.
19. Reinstall the fluid body, outlet cap and tighten the three bolts to 30 to 35 inch pounds.

## Accessories

### 1/4 NPT Metal Nozzles

Stainless steel, 38.1 mm (1.5") long. ID Size

Part #	Gauge	mm	(Inches)
5007-1/4 NPT	7	3.81	(.150)
5008-1/4 NPT	8	3.43	(.135)
5010-1/4 NPT	10	2.69	(.106)
5012-1/4 NPT	12	2.16	(.085)
5014-1/4 NPT	14	1.60	(.063)
5016-1/4 NPT	16	1.20	(.047)

### Polyethylene Nozzles

Plastic nozzles with 1/4 NPT thread. Nozzles may be cut or shaped as required. Supplied (10) nozzles per package.

Part #	Size
5180-B	63.5 mm long x 3.2 mm opening (2 1/2" x 1/8")
5181-B	63.5 mm long x 1.6 mm opening (2 1/2" x 1/16")
5182-B	101.6 mm long x 1.6 mm opening (4" x 1/16")
5183-B	101.6 mm long x .8 mm opening (4" x 1/32")

### Dispensing Tip Adapter

Accepts all EFD dispensing tips.

Part #	Material
7405MT-1/4	Adapter for use with metal tips
7405-1/4	Adapter for use with disposable plastic tips

(continued on back cover)



### Maintenance Tools:

- 1/8" Allen wrench
- 5/32" Allen wrench
- (2) 8" adjustable wrenches

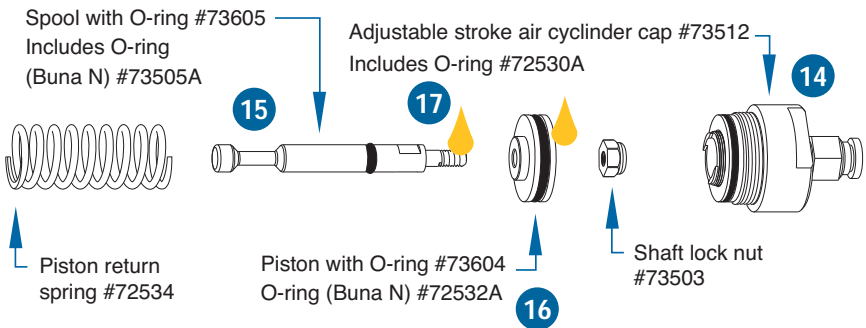

# Troubleshooting Guide

## No fluid flow

- If valve operating pressure is too low, the valve will not open. Increase air pressure to 70 psi (4.8 bar) for timed shots and 40 psi (2.7 bar) minimum for stripes.
- The fluid pressure may not be high enough. Increase pressure.
- The dispensing tip may be clogged. Replace tip.
- Fluid may have solidified in the fluid body. Clean the fluid body.

## Fluid drools after the valve closes, eventually stopping

- This is caused by air trapped in the outlet section of the fluid body or the fluid has entrapped air. The air will expand after the valve closes, causing extrusion until the air reaches atmospheric pressure. Purge the valve by dispensing at a steady flow until air is removed.
- If the fluid has entrapped air, it must be degassed before dispensing.

## Fluid drips at a steady rate after the valve closes

- A steady drip indicates failure of the seal due to particle build-up or wear. Replace the seal.

## Valve responds slowly when opening and closing

- Valve response is related to control air line length and size. EFD valves are supplied with 5-feet of 4 mm (5/32") ID tubing attached. Any additional length or size change will affect response time. Check to be sure the length and size have not been changed.

## Fluid flows out above upper seal

- Fluid flowing out above the upper seal indicates a worn upper seal. Replace seal.

## Inconsistent deposits

- Inconsistent deposits can result if the air pressure controlling the valve and/or fluid pressure is fluctuating, or if the valve operating pressure is less than 70 psi (4.8 bar). Check air pressures and the valve operating pressure.
- The time the valve is open must be consistent. Check to be sure the valve controller is providing a consistent output.

## Accessories (continued)

### Valve Mounting Rod

Mounting rod dimensions are 177.8 mm long x 12.7 mm (7" x 1/2") diameter with 5/16 – 24 UNF thread.

Part #	Description
73522	Mounting rod for the 736HPA valve

### Universal Valve Mount

Use with all EFD valves for easy valve mounting.

Part #	Description
7002VM	Universal valve mount

### Double-Acting Air Closure Kit

The 735AC-KIT is used in applications dispensing very thick fluids at high cycle rates. The air closure assists the spring to provide a quick, clean cut-off at the end of the dispense cycle.

Part #	Description
735AC-KIT	Air closure kit



USA: 800-556-3484 or +1-401-434-1680  
Europe: 0800 585733 or +44 (0) 1582 666334  
Asia: +86 (21) 5854 2345  
technical@efd-inc.com      www.efd-inc.com