

782RA Spray Valve

MAINTENANCE & PARTS GUIDE

Electronic pdf files of EFD® manuals are also available at www.efd-inc.com/manuals.html.

IMPORTANT!
Save this Sheet.

**Forward to
Maintenance or
Tool Crib
Supervisors**



For EFD sales and service in over 30 countries,
contact EFD or go to www.efd-inc.com/contact

EFD, Inc.

East Providence, RI USA
800-556-3484; +1-401-434-1680 (outside the USA)
info@efd-inc.com www.efd-inc.com

EFD International Inc.

Dunstable, Bedfordshire, UK
0800 585733 or +44 (0) 1582 666334
Ireland 00800 8272 9444
europe@efd-inc.com www.efd-inc.com

EFD, Inc., Asia

China: +86 (21) 5854 2345
china@efd-inc.com www.efd-inc.com/cn
Singapore: +65 6896 9630 sin-mal@efd-inc.com

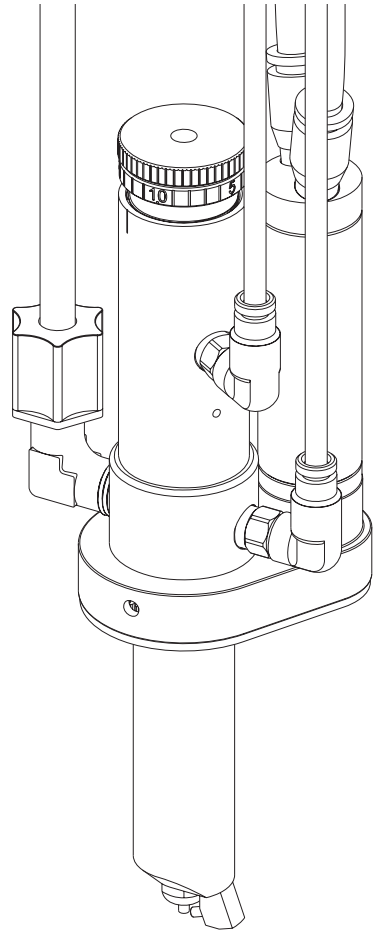

Valve Disassembly and Reassembly Procedures

Valve maintenance

To thoroughly clean the fluid body and replace needle packings:

1. Remove needle stroke control knob and spring.
2. Remove the gear cover.
3. Remove the rotor retainer nut, then the rotor, nozzle, fittings and motor from the fluid body.
4. Remove the motor mount and motor assembly.
5. Remove the fluid body from the air cylinder body. Remove the O-ring from the fluid body.
6. Clean the fluid body, rotor and nozzle in appropriate solvent.

Note: Rotor bearings can be soaked in light oil for one hour to penetrate past the seals. Replace bearings if rotor does not rotate smoothly.

7. Use tool #7803 to remove needle packings from fluid body.
8. Remove any remaining packings and the spring from the needle.

Note: The lower cylinder needle O-ring is held in place by a flat retaining washer that also serves as the packing-spring seat. The washer may come out with the spring. Ensure that it is back in place before reinstalling the packing spring.

9. Clean the needle with a cloth dampened in solvent.

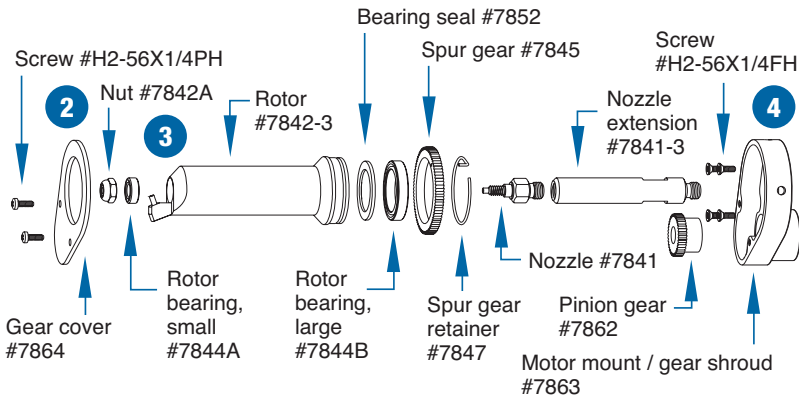

- Lubricate the needle with Nye Lubricant #865. Reinstall the needle packing spring and a new packing kit.
- Install a new O-ring (#7517) on the fluid body.
- Reassemble valve in reverse order.

Replacing piston and needle assembly or piston O-ring:

- Remove needle stroke-control knob.
- Remove piston return spring and thrust washers.
- Remove the snap ring.
- With small pliers on the spring pilot, pull the piston and needle assembly out of air cylinder. The piston and needle assembly is one unit and cannot be disassembled.

- Clean air cylinder body wall and lubricate with Nye Lubricant #865.
- Reassemble the valve in reverse order.

General Maintenance Kit #780S-RK

Includes O-rings, needle-packing assembly and lubricant.

Maintenance Tools:

6" adjustable wrench
5/16" open-end wrench
snap-ring pliers
packing extraction tool #7803

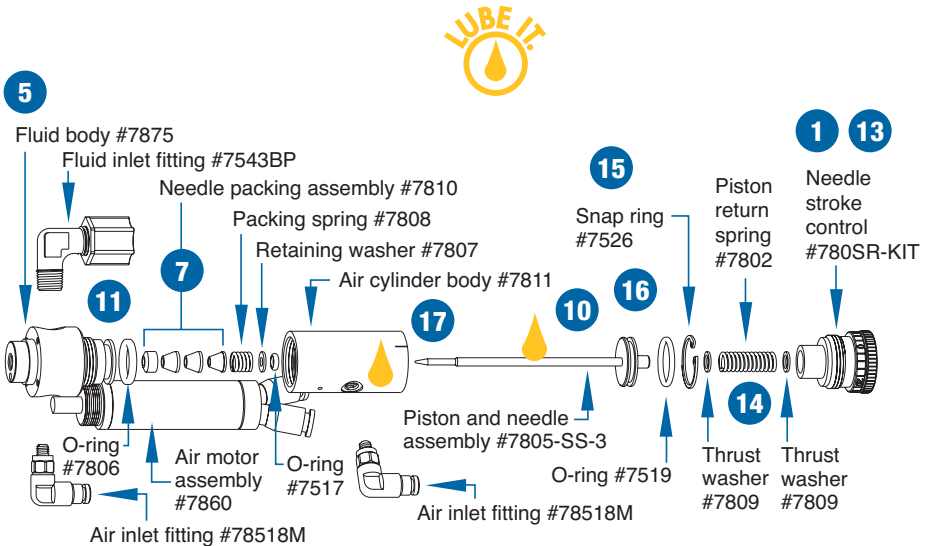

Troubleshooting Guide

No fluid flow

- If valve operating air pressure is too low, the valve will not open. Increase air pressure to 70 psi (4.8 bar) minimum.
- The reservoir air pressure may not be high enough. Increase pressure.
- The nozzle may be clogged. Clean the nozzle.
- The stroke adjustment control may be closed. If it is closed, open counterclockwise one turn.
- The control and the atomizing air lines may be reversed. Check for proper connection.

Valve does not provide clean shut-off, leaving a build-up on the nozzle

- Atomizing air pressure may be too low. Increase the air pressure.
- Atomizing air delay setting may be too low. Increase air delay setting.

Fluid continuously drips from the nozzle after the valve shuts off

- A continuous drip can be caused by improper seating of the needle in the nozzle seat. Remove the nozzle, clean the needle and nozzle, and replace worn or damaged parts.
- If the fluid body has not been fully turned onto the air cylinder body during reassembly, the needle will not seat in the nozzle. Check fluid body installation.
- Needle packings may be binding due to leakage, preventing the needle from fully closing. Disassemble the valve and replace the packings if there is evidence of leakage.

Fluid flows from the nozzle but will not spray

- Atomizing air pressure may be too low. Increase air pressure.
- If the fluid viscosity is too high, it will not atomize. Reduce viscosity.
- Check atomizing hose connection "B" at the controller.



USA: 800-556-3484 or +1-401-434-1680
Europe: 0800 585733 or +44 (0) 1582 666334
Asia: +86 (21) 5854 2345
technical@efd-inc.com www.efd-inc.com