

# 741V

## MAINTENANCE & PARTS GUIDE

Electronic pdf files of EFD manuals are also available at [www.efd-inc.com/manuals.html](http://www.efd-inc.com/manuals.html).

**IMPORTANT!**  
**Save this Sheet.**  
**Forward to**  
**Maintenance or**  
**Tool Crib**  
**Supervisors**



**For EFD sales and service in over 30 countries,  
contact EFD or go to [www.efd-inc.com/contact](http://www.efd-inc.com/contact)**

**EFD, Inc.**

East Providence, RI USA  
800-556-3484; +1-401-434-1680 (outside the USA)  
[info@efd-inc.com](mailto:info@efd-inc.com) [www.efd-inc.com](http://www.efd-inc.com)

**EFD International Inc.**

Dunstable, Bedfordshire, UK  
0800 585733 or +44 (0) 1582 666334  
Ireland 00800 8272 9444  
[europe@efd-inc.com](mailto:europe@efd-inc.com) [www.efd-inc.com](http://www.efd-inc.com)

**EFD, Inc., Asia**

China: +86 (21) 5854 2345  
[china@efd-inc.com](mailto:china@efd-inc.com) [www.efd-inc.com/cn](http://www.efd-inc.com/cn)  
Singapore: +65 6896 9630 [sin-mal@efd-inc.com](mailto:sin-mal@efd-inc.com)

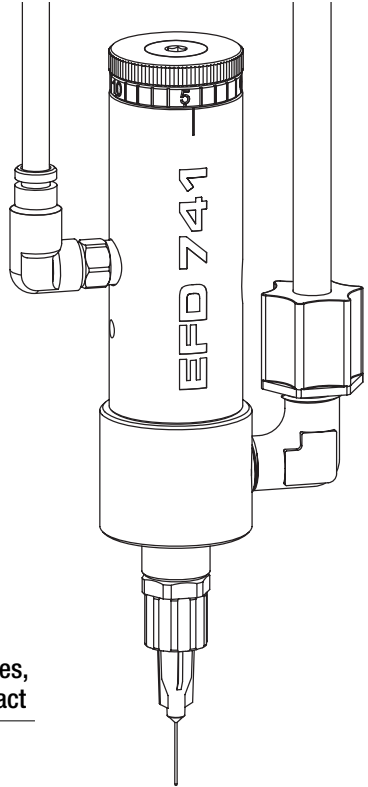

# Valve Disassembly and Reassembly Procedures

**CAUTION:** To prevent damage, the valve must be disassembled starting at the fluid outlet end of the valve.

## Valve maintenance

To thoroughly clean fluid body and replace needle packings:

1. Remove needle stroke control knob and spring.
2. Remove inlet fitting and tip adapter/seat assembly.
3. Remove fluid body from air cylinder body, then remove O-ring.
4. Use extraction tool #7803 to remove needle packings from fluid body.
5. Remove any remaining packings and spring from needle.
6. Clean needle with cloth dampened in solvent, and lubricate with Nye Lubricant #865 included in the Maintenance Kit.

7. Replace O-ring and reassemble the valve in reverse order of disassembly.

**Note:** Ensure that the lower cylinder needle O-ring is back in place before reinstalling the packing spring.

## Replacing piston and needle assembly or piston O-ring

8. Remove needle stroke control knob.
9. Remove piston return spring and thrust washers.
10. Remove the snap ring.
11. With small pliers on the spring pilot, pull the piston and needle assembly out of air cylinder. The piston and needle assembly is one unit and cannot be disassembled.
12. Clean air cylinder body wall and replace piston O-ring. Lubricate with Nye Lubricant #865 included in the Maintenance Kit.

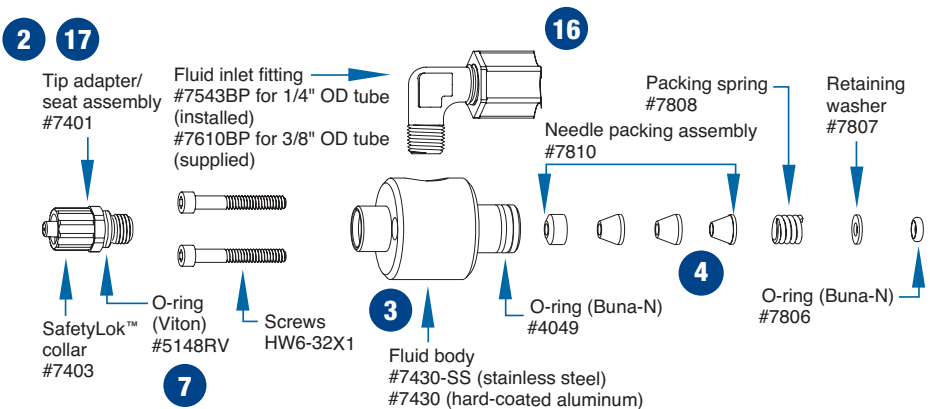

13. Reassemble the valve in reverse order of disassembly.

14. Leak test the valve (see below).

## Leak testing

15. Set the needle stroke control at two turns open.

16. Shut off actuating air. Install an air hose in the fluid inlet and connect it to a 100 psi (7 bar) air supply.

17. Submerge tip adapter/seat assembly in water. If air bubbles appear, reseal the parts (see next steps).

## Reseating the needle and tip adapter assembly

18. Disconnect all air to the valve.

19. Rotate the stroke adjustment knob to the closed position.

20. To compress the needle into the tip adapter, further rotate the stroke adjustment clockwise one additional reference mark.

21. Return stroke adjustment to normal setting and cycle the valve. If a slight leak remains, repeat steps 1 and 2.

22. If the leak persists, replace the tip adapter.

## Maintenance Kit

### #741V-RK

Includes all O-rings, needle packing assembly and lubricant.

## Tools required:

6" Adjustable wrench

Snap-ring pliers

Packing extraction tool (#7803)

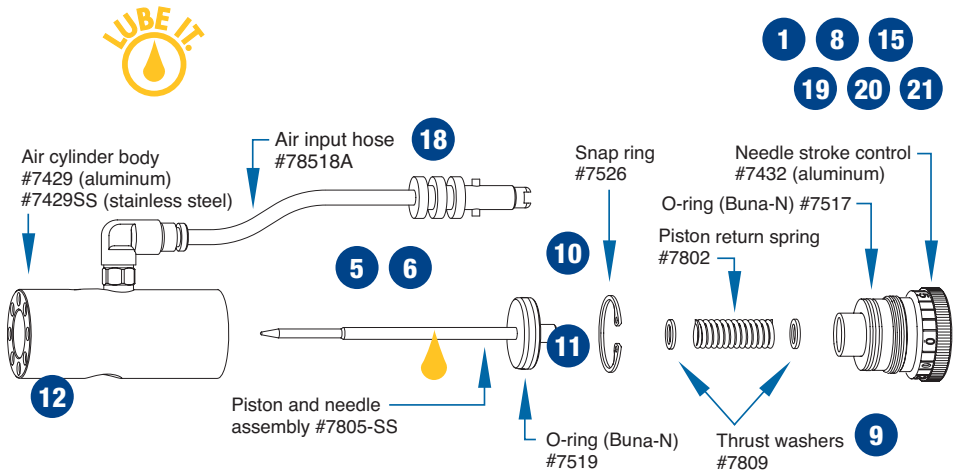

# Troubleshooting Guide

## No fluid flow

- If valve operating air pressure is too low, the valve will not open. Increase air pressure to 70 psi (4.8 bar) minimum.
- The reservoir air pressure may not be high enough. Increase pressure.
- The needle stroke adjustment may be closed. Open stroke adjustment.
- Material may have clogged the fluid body or output tip adapter. Clean the valve.

## Steady drip

- A steady drip can be caused by a worn needle and seat, or a particle holding the needle off the seat. Clean and inspect the needle and seat for wear. Replace worn or damaged parts.

## Fluid leaks out the drain hole

- Fluid leaking out the drain hole on the side of the valve indicates the needle packings are worn. Replace needle packings.

## Inconsistent deposits

- Inconsistent deposits can result if the air pressure controlling the valve and/or supplying the reservoir is fluctuating or if the valve operating pressure is less than 70 psi (4.8 bar). Check to be sure air pressures are constant and the valve operating pressure is 70 psi (4.8 bar).
- The time the valve is open must be constant. Check to be sure the valve controller is providing a consistent output.



USA: 800-556-3484 or +1-401-434-1680  
Europe: 0800 585733 or +44 (0) 1582 666334  
Asia: +86 (21) 5854 2345  
technical@efd-inc.com      www.efd-inc.com