

ULTRASAVER™ USER GUIDE

1200 • 1215



USA: 800-556-3484
In the UK: 0800 585733
In Mexico: 001-800-556-3484

EFD®
A NORDSON COMPANY

Setting up the ULTRASAVER™

Note: Clean, dry, filtered air is required to meet warranty. If necessary, use five-micron filter regulator (not supplied – order #2000F755).

1. Connect ULTRASAVER (or filter regulator where required) to plant air supply.
2. If appropriate, connect ULTRASAVER to filter regulator. Press air hose firmly into fittings to connect.
3. Set plant air supply (or filter regulator) within 80 to 100 psi (5.4 to 7.0 bar).
4. Plug in the foot pedal.
5. Set voltage selector switch to the proper value.
6. Connect power cord.
7. Attach the hose support to desired side of the ULTRASAVER.
8. Position barrel adapter hose in the support and connect to the ULTRASAVER's output.
9. Turn power switch on (rear panel).

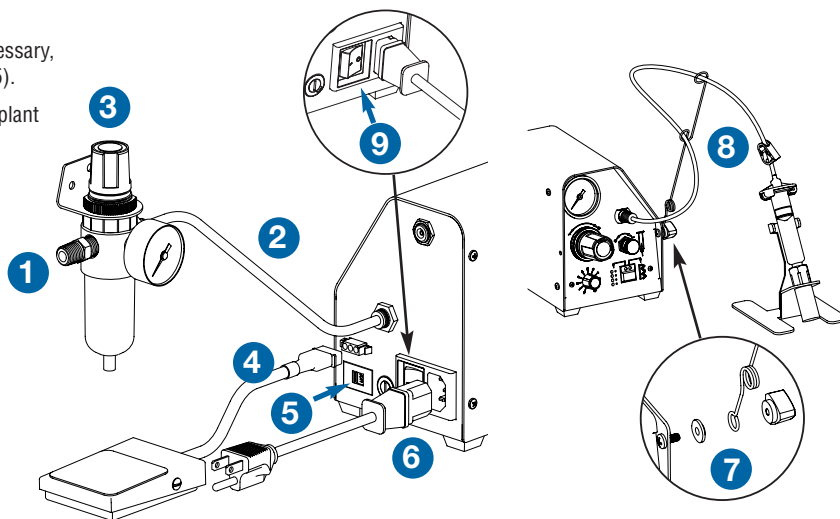

Filling barrels

Thin, pourable fluids

Twist on a tip cap and pour fluid in.

If appropriate, insert the SmoothFlow™ piston.

Carefully press the piston down (use a pen or pencil) until it contacts the fluid.

Attach barrel to barrel adapter assembly.

Invert barrel, replace tip cap with selected dispense tip.

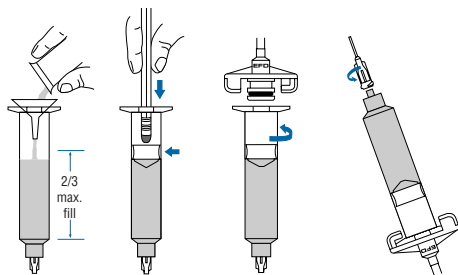

Solvents, cyanoacrylates or anaerobics

Same procedure as with thin, pourable fluids EXCEPT:

Use the blue LV Barrier™. Place barrier in the TOP of the barrel reservoir.

Allow air between barrier and fluid. (Do not contact the blue barrier to the fluid.)

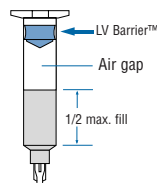

Thick or non-leveling materials

Same procedure as with thin, pourable fluids EXCEPT:

Spoon fluid into the barrel with a spatula. (If packed in a 1/10 gallon cartridge, try loading the barrel with a caulking gun.)

Note: Move the fluid toward the bottom of the barrel by pressing the SmoothFlow™ piston. Squeeze barrel sides slightly to allow trapped air to escape.

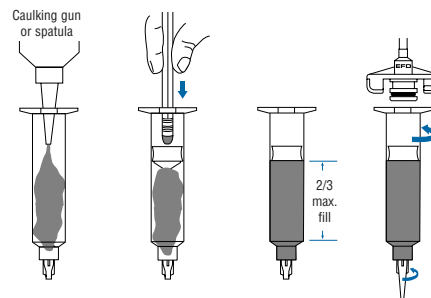

THICK fluid settings

1. Set air pressure to 30 psi

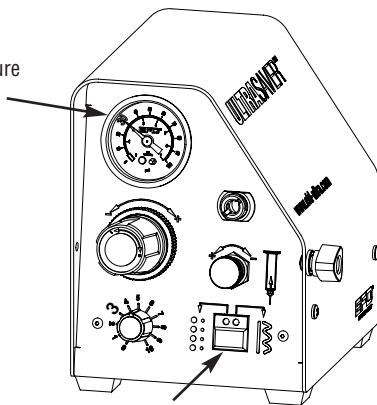

2. To fill tip, set mode switch to steady (yellow light on) and press foot pedal.
3. If dots are required, reset mode switch to green. Set time at #3, adjust as necessary.

THIN fluid settings

1. Set air pressure to 2 psi

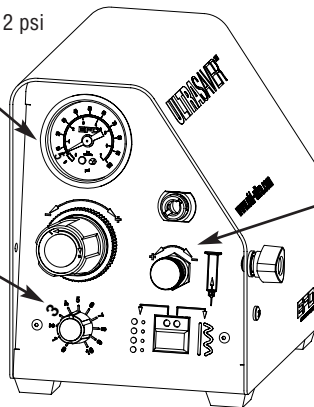

2. Set time at #3

3. If drop forms at tip, turn vacuum control counter-clockwise until drop disappears.

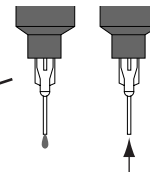

Note: Settings are general recommendations. For best results, test settings for your specific application.

How to make DOTS

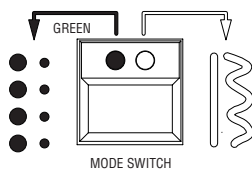

Press the mode switch so the green light is lit.

Hold the barrel at 45°.

Place tip on work surface. Press the foot pedal to repeat the same size dot.

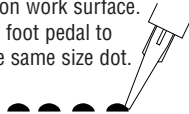

How to make STRIPES

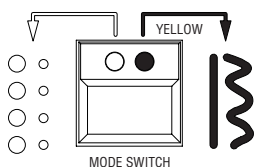

Press the mode switch so the yellow light is lit.

Hold the barrel at 45°.

Place tip on work surface.

Use the foot pedal to control flow.

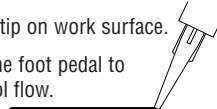

Time range adjustments – special setups

Most applications work best with ULTRASAVER's default time setting (shipped with 0.010 – 1.000 momentary). However, for special setups the ULTRASAVER's time range may be adjusted with the rotary switch located under the plug in the bottom panel of the cabinet.

To change the time range, rotate the switch to the desired setting using a small screwdriver. Replace plug.

In maintained mode, the foot pedal must remain depressed throughout the entire dispense cycle. Releasing the pedal during a cycle will interrupt the cycle.

In momentary mode, the foot pedal can be pressed and immediately released, and the cycle will continue. If the pedal is pressed again during a cycle, the dispenser will stop.

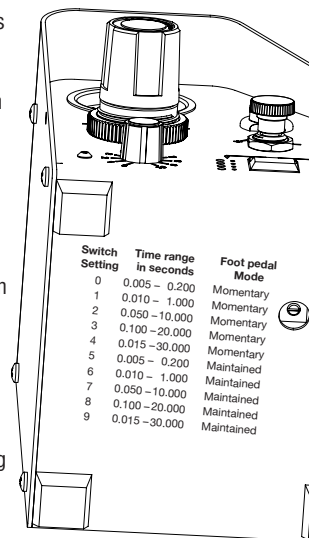

Technical specifications

Input voltage: 100-120/208-240 VAC, 50/60 Hz, 8VA max.

Fuse rating: 80 mA, 250V, Type T

Air input pressure: 80 – 100 psi (5.5 – 6.9 bar)
Use only clean, dry, filtered air – minimum 20 micron

Air output pressure: 1200: 0 – 100 psi (0 – 6.9 bar)
1215: 0 – 15 psi (0 – 1.03 bar)

Dimensions: 4-3/4" w x 6" h x 5-1/2" d
(120.7mm x 152.4mm x 139.7mm)

Weight: 2.78 lbs. (1.26 kg)

Enclosure rating: NEMA 1 or IP100

Time ranges: 0.005 – 0.200 seconds
0.010 – 1.000 seconds (momentary, default)
0.050 – 10.000 seconds
0.100 – 20.000 seconds
0.015 – 30.000 seconds

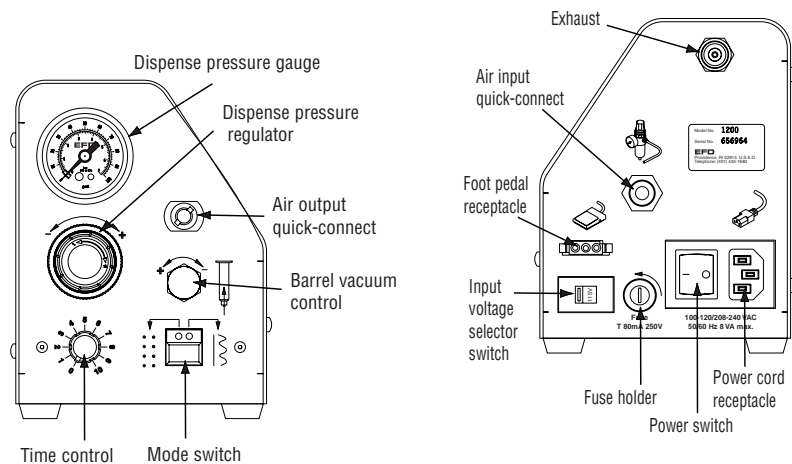

For assistance or to order EFD ULTRA dispensing components, contact your local EFD authorized distributor.

EFD Two Year Limited Warranty

All components of EFD dispensers are warranted to the original end user for two years from date of purchase.

Within the period of this warranty, EFD will repair or replace free of charge any defective component on return of the part, or the complete dispenser, prepaid to the factory.

In no event shall any liability or obligation of EFD arising from this warranty exceed the purchase price of the equipment. Before using, user shall determine the suitability of the product for his intended use, and user assumes all risk and liability whatsoever in connection therewith. This warranty is valid only when clean, dry, filtered air is used.

EFD makes no warranty whatsoever of merchantability or fitness for a particular purpose. In no event shall EFD be liable for incidental or consequential damages.

EFD[®]
A NORDSON COMPANY

Headquarters:
977 Waterman Avenue, East Providence, RI 02914-1342 USA
USA: 800-556-3484 Mexico: 001-800-556-3484
Telephone: 401-434-1680 Fax: 401-431-0237
e-mail: ultrasaver@efd-inc.com www.efd-inc.com

Unit 14, Apex Business Centre, Boscombe Road
Dunstable, Bedfordshire LU5 4SB UK
Telephone: 01582 666334 Fax: 01582 664227
Freephone: 0800 585733 From Ireland: 00800 8272 9444



This equipment is regulated by the European Union under WEEE Directive (2002/96/EC). See www.efd-inc.com for information about how to properly dispose of this equipment.

Sales and service of EFD dispensers and dispensing components are available through EFD authorized distributors in over 30 countries. Please contact EFD U.S.A. for specific names and addresses.