

HP7^x™

EFD®
A NORDSON COMPANY

US: 800-556-3484

UK: 0800 585733

Mexico: 001-800-556-3484

technical@efd-inc.com



USER'S GUIDE

Setup and Operation

Step 1.
Remove reservoir
retainer

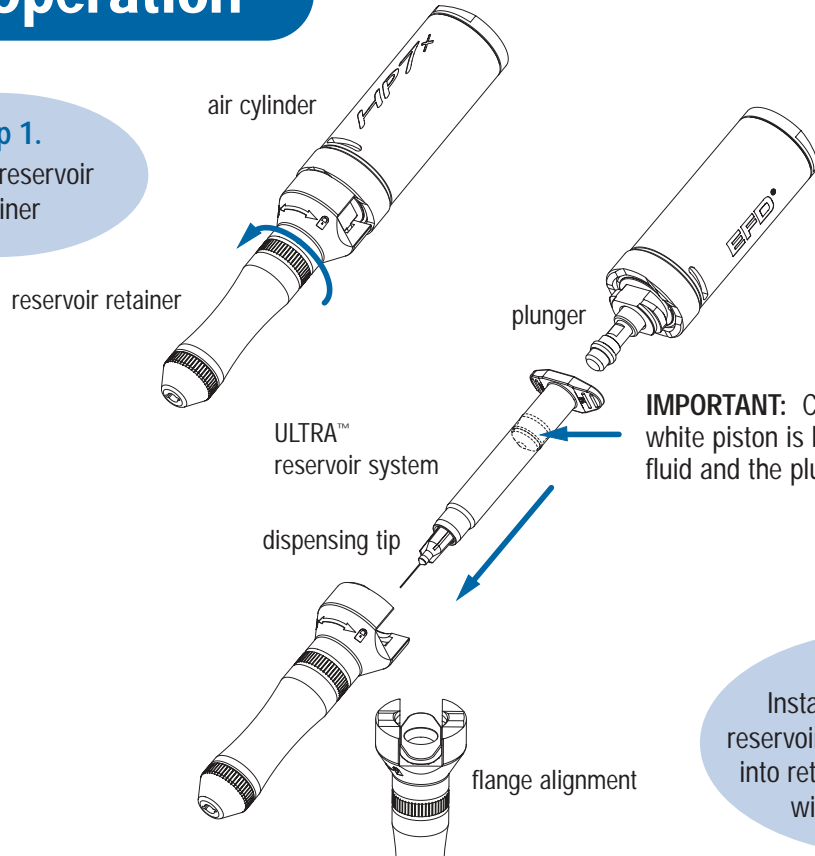

IMPORTANT: Confirm that a white piston is between the fluid and the plunger.

Step 2.
Install dispensing tip on
reservoir. Insert filled reservoir
into retainer and align flange
with slot as shown.

Step 3.

Install retainer and rotate clockwise to secure. Connect HP7x to EFD air-powered dispenser. Insert air quick-connect into air outlet and turn clockwise to lock.

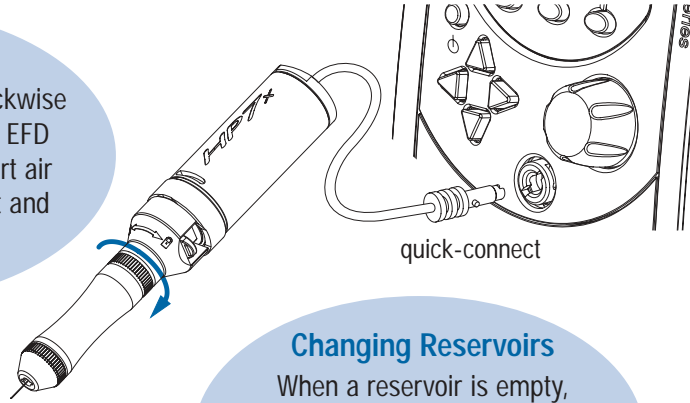

Changing Reservoirs

When a reservoir is empty, the window in the air cylinder will turn red. Remove reservoir retainer. Then, remove empty reservoir and discard.

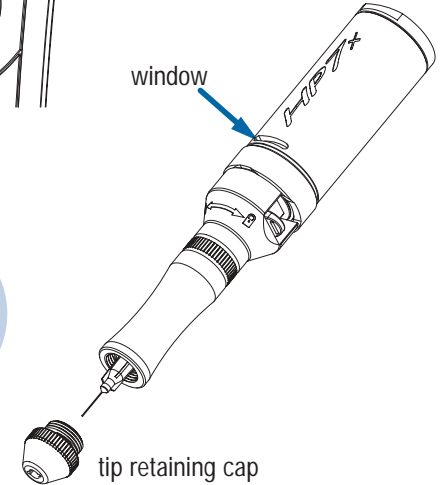

Changing Tips

Remove tip retaining cap and invert. Align slot with wings on dispensing tip. Turn tip retaining cap counterclockwise to remove tip. Attach a new tip and tighten tip retaining cap securely.

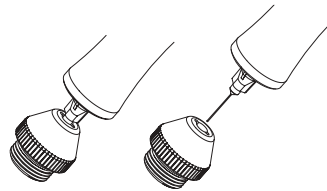

Note: Refer to EFD dispenser operating instructions to control deposit size with time and pressure.
Do not reuse reservoirs! Wipe plunger clean (if necessary) before installing a new reservoir.

For parts list, see back cover.

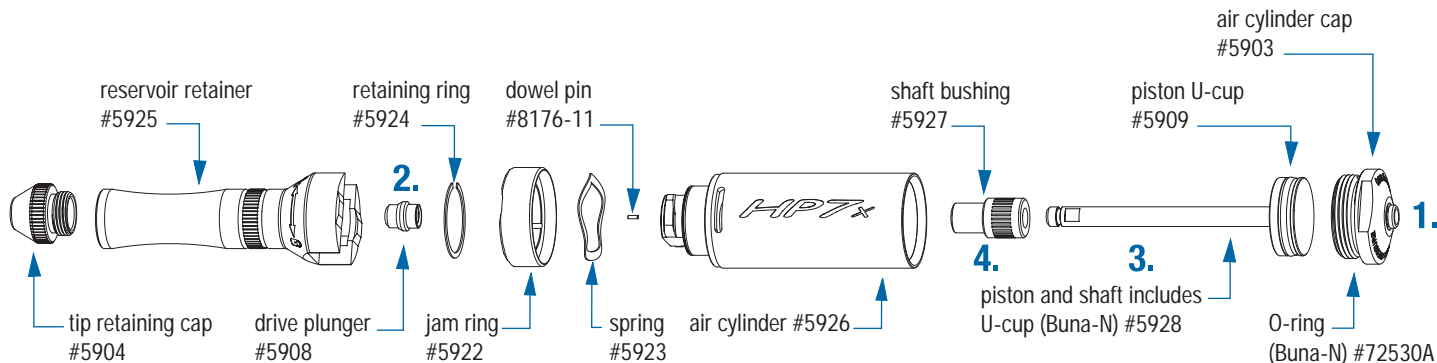

HP7x Troubleshooting

If the HP7x should cease to operate, service of the piston U-cup and shaft bushing may be required. Please follow procedure below:

1. Remove air cylinder cap.
2. Remove drive plunger.
3. Remove piston and shaft assembly. Replace piston U-cup and lubricate lightly with O-ring grease.
4. Press shaft bushing (#5927) out from bottom of cylinder toward piston chamber. Replace with new bushing.
5. Install piston assembly and reinstall the air cylinder cap and drive plunger.

EFD[®]
A NORDSON COMPANY

977 Waterman Avenue, East Providence, RI 02914-1378 USA
 US: 800-556-3484 Mexico: 001-800-556-3484 Telephone: 401-434-1680
 Fax: 401-431-0237 e-mail: technical@efd-inc.com www.efd-inc.com

Unit 14, Apex Business Centre, Boscombe Road, Dunstable, Bedfordshire LU5 4SB UK
 UK: 0800 585733 Ireland: 00800 8272 9444 Telephone: 01582 666334
 Fax: 01582 664227 e-mail: uk@efd-inc.com

Sales and service of EFD dispensers and dispensing components are available through EFD authorized distributors in over 30 countries. Please contact EFD USA for specific names and addresses.

EFD and HP7x are trademarks of EFD, Inc. ©2004 EFD, Inc. HP7X-MAN-01 v102704