

EFD ONE YEAR LIMITED WARRANTY

All components of the EFD ValveMate 7040 are warranted for one year from date of purchase to be free from defects in material and workmanship (but not against damage caused by misuse, abrasion, corrosion, negligence, accident, faulty installation or by dispensing material incompatible with equipment) when the equipment is installed and operated in accordance with factory recommendations and instructions. EFD will repair or replace free of charge any part of the equipment thus found to be defective, on authorized return of the part prepaid to our factory during the warranty period.

In no event shall any liability or obligation of EFD arising from this warranty exceed the purchase price of the equipment. This warranty is valid only when oil-free, clean, dry, filtered air is used.

EFD makes no warranty of merchantability or fitness for a particular purpose. In no event shall EFD be liable for incidental or consequential damages.

China RoHS Hazardous Material Declaration

Part Name	Toxic or Hazardous Substances and Elements					
	Lead (Pb)	Mercury (Hg)	Cadmium (Cd)	Hexavalent Chromium (Cr6)	Polybrominated Biphenyls (PBB)	Polybrominated Diphenyl Ethers (PBDE)
All brass fittings	X	0	0	0	0	0
<p>0: Indicates that this toxic or hazardous substance contained in all the homogeneous materials for this part, according to EIP-A, EIP-B, EIP-C is below the limit requirement in SJ/T11363-2006.</p> <p>X: Indicates that this toxic or hazardous substance contained in all the homogeneous materials for this part, according to EIP-A, EIP-B, EIP-C is above the limit requirement in SJ/T11363-2006.</p>						

Contents

Warranty.....	inside cover
Introduction and Specifications	2
Operating Features	3
Typical Setup.....	4
Setup	5-6
Adjusting the Spray.....	7
Programming Nozzle Air Delay	8
Schematic and Replacement Parts	9
Troubleshooting Guide	10
Input / Output Connections.....	11-12
Connecting More than One 7040 Controller.....	13

Introduction

The ValveMate 7040 provides easy adjustment of valve output for maximum end-user convenience and efficiency. Designed for use with the 781S Series spray valves, the ValveMate 7040 features an adjustable nozzle air-flow regulator and a microprocessor-based timed air-pressure output for controlling valve ON time. The ValveMate 7040 is simple to use and will operate many millions of cycles without maintenance.

Specifications

The small size and adjustable mounting bracket allow for positioning of the ValveMate close to the point of valve operation and provide convenient access to setup and dispensing adjustment controls.

“On the fly” time adjustment allows adjustment of valve output while the equipment is running. This feature eliminates the need to shut down parent machinery to change or adjust dispense time settings.

Other features and explanations of controls are detailed in the diagrams on pages 4 and 5.

Note: Specifications and technical details are subject to engineering changes without prior notification.

Size:	19 cm W x 14 cm D x 7 cm H (7.5" W x 5.6" D x 2.7" H)
Weight:	1.4 kg (3.1 lb)
Cabinet:	Aluminum
Input Voltage:	Selectable 100/120/220 VAC
Internal Voltage:	24 VDC
Feedback Circuits:	5 to 24 VDC NC solid-state switch 250mA maximum
Initiate Circuit:	5 to 24 VDC signal or contact closure
Air Input:	70 psi (4.8 bar)
Cycle Rate:	Exceeds 600 per minute
Time Range:	.001 to 99.9 seconds

Meets CE standards.

Operating Features

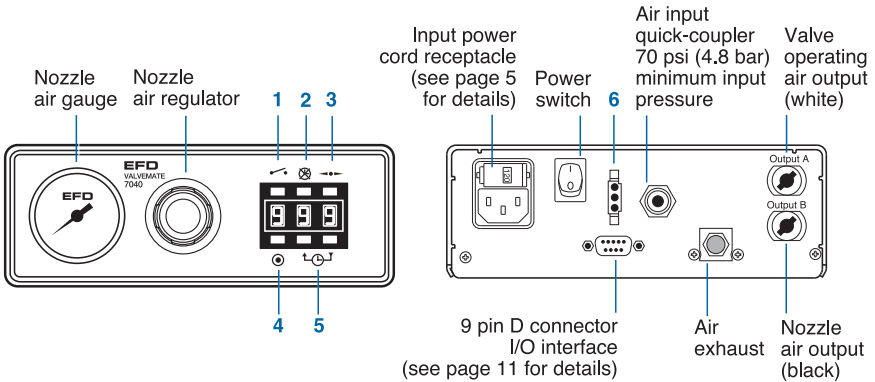

1. Cycle

Press to initiate one complete dispense cycle. Press again to interrupt a timed cycle. Press and hold while in the time override mode for continuous cycle. Release to stop.

2. Time override

Press to override time control. Display will show (---). While in this mode, dispensing is manual using the cycle button, voltage initiate source or foot pedal (optional, #2015A).

3. Decimal

Press to move decimal and change time range maximums from .999 to 9.99 or 99.9. Decimal does not appear in the display while in the .999 second range.

4. Program

Press to clear display to zeros. Display flashes bright/dim while in program mode.

Press cycle button and hold until proper amount is sprayed. Total spray time will be displayed. Press program button again to lock in spray time.

5. Time set

Press to change time setting up or down. Press and release to advance one digit at a time, or press and hold to scroll quickly.

6. Foot pedal connector

If using the optional foot pedal, press the pedal momentarily to initiate the controller. To interrupt a timed dispense cycle, press the pedal again.

Typical Setup

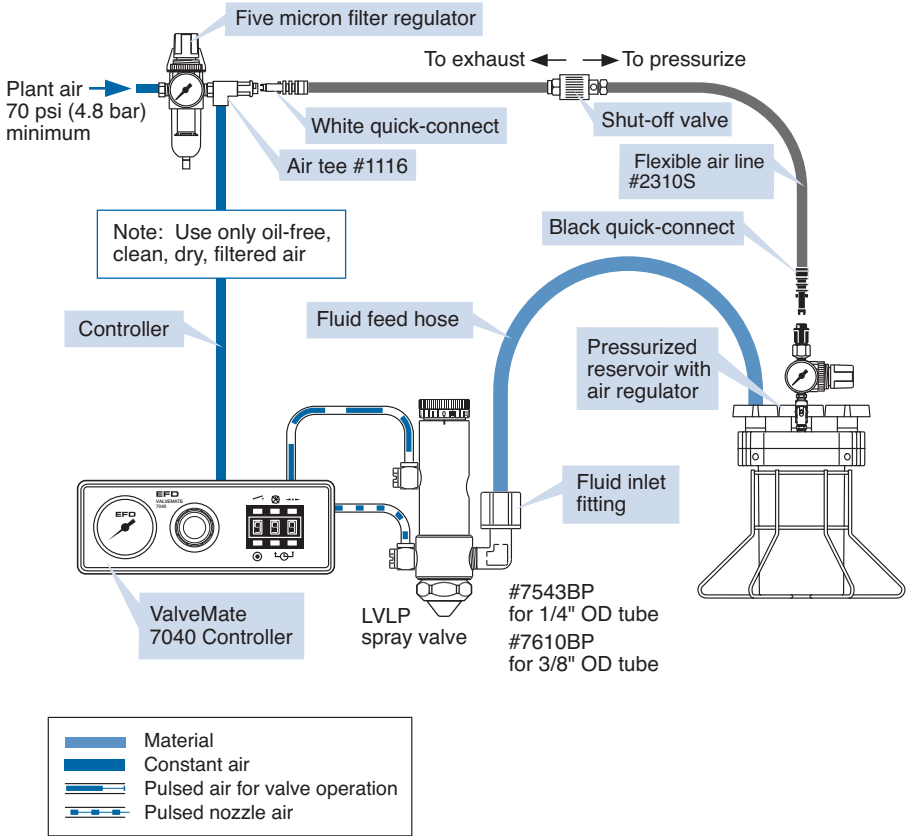

Caution: Always depressurize the reservoir before opening. To do this, slide the shutoff valve on the air line away from the reservoir. If using an EFD tank, open the pressure relief valve as well. Before opening the reservoir, check the pressure gauge to verify that pressure is zero (0). On all EFD cartridge reservoirs, the unique threaded design provides fail-safe air pressure release during cap removal.

Setup

① Mounting

Use the universal mounting bracket (included) to mount the controller either over or under the cabinet. The bracket allows the controller to pivot 30° from a horizontal position. For panel mounting, a panel mount bracket kit is available (#7000PMK).

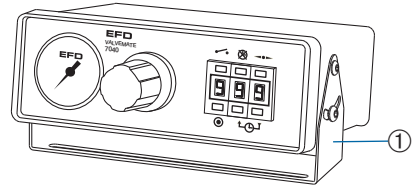

② Input Power

1. View cartridge window in power cord receptacle to ensure that the voltage is set properly. Selections are 100, 120 or 220 VAC.
2. If it does not match, remove the fuse cartridge. Then remove the fuse holder from the cartridge, rotate the holder and position the correct voltage to show through the cartridge window. Reassemble in reverse order.
3. Connect the power cord.

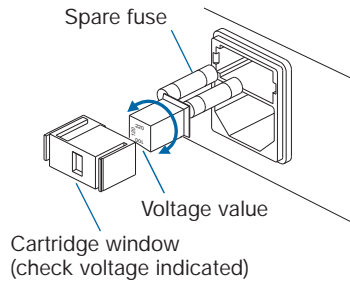

Setup

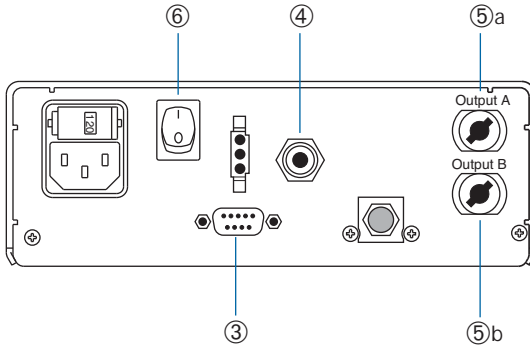

③ Initiate Connection

The 7040 can be operated by applying a 5 to 24 VDC pulse to terminal pins 1 and 2, or providing contact closure across pins 5 and 7. Alternatively, a foot pedal may be ordered (#2015A) and plugged into the connector located on the rear panel.

④ Air Input Connection

1. Connect the controller to plant air by first installing the five micron filter regulator (#2000F755) to the plant air supply.
2. Install the air tee with barb fitting (#1116 supplied with EFD tank reservoirs) in the output of the filter regulator, and install the black hose with coupling to the barb fitting. The quick-connect on the air tee is used to provide air pressure to the air pressure regulator on EFD tank reservoirs. This connection will be made during valve installation.

3. Remove the cap plug from the air input of the controller and attach the input air hose coupling onto the controller air-input fitting.
4. Set the pressure at the filter regulator to 70 psi (4.8 bar).

⑤ Control Air Output

The 781S is equipped with nozzle and control air hoses with male quick-connects that plug into the ValveMate 7040.

- a) Plug the control air hose labeled "A" into output "A" (white) of the 7040.
- b) Plug the nozzle air hose labeled "B" into output "B" (black).

⑥ Power

1. Turn the power switch on.
2. Press the time override button to place the controller in manual mode (---).

Adjusting the Spray

1. Turn the nozzle air pressure on the controller to zero. Using the needle stroke control knob ① on the 781S valve, set the fluid flow rate to one or two drops per second. Check flow rate by actuating the controller in the time override mode. Make valve stroke adjustments when the controller is off.
2. Set the nozzle air pressure on the controller to 10 psi (0.7 bar) and actuate the controller. The valve will produce a fine spray.
3. To change fluid flow, use the needle stroke control knob ①, and/or tank air pressure.

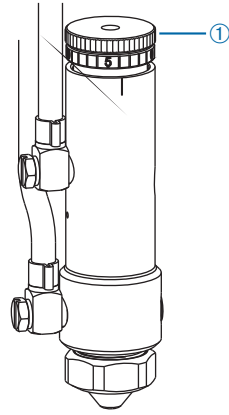

Note: Avoid tight stroke settings with high tank pressure.

4. To change nozzle air, use the nozzle air pressure regulator ②. Higher pressures will provide finer spray.

To Make Timed Deposits

1. Return to the time control by pressing the time override button ③. The display should show the time setting.
2. Adjust the deposit time to 0.5 seconds by using the time set ④ and decimal ⑤ buttons.
3. Press the cycle button ⑥. The controller will open the valve for 0.5 seconds. Adjust time and test deposits until desired output is obtained.

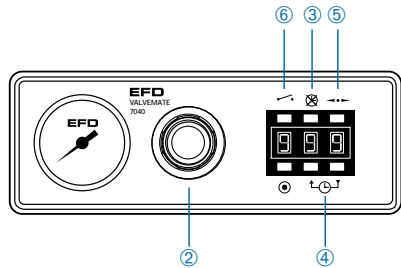

Note: Optimal results will be obtained with the proper combination of time setting, needle stroke control knob, and reservoir and nozzle air pressure.

Programming Nozzle Air Delay

Nozzle air delay is the time the nozzle air continues to spray after the fluid is turned off. When spot marking with low viscosity fluids, the delay can be reduced to prevent blowing out the center of the mark. The delay can be increased with high viscosity fluids and greases to provide a spreading out effect.

1. Turn the power switch off.
2. Press and hold the time override button while turning power switch on.
3. The display will read "SEL" (select). Release the time override button.
4. Press either the up or down time set buttons once and release. The current nozzle air-delay setting will be displayed. (The delay is preset to 0.24 seconds for all new controllers.)
5. Press the up or down time set button again to program the new nozzle air delay. (Available range is 0.00 to 2.50 seconds.)
6. To exit the nozzle air-delay program mode, momentarily press the time override button. The spray time setting will be displayed.

Note: The controller will not operate while in the nozzle air delay program mode.

Schematic and Replacement Parts List

- | | | | |
|-----------------|---|--------------|---------------------------------------|
| 1. 2-2002-7040 | Regulator assembly
0 to 30 psi, 0 to 2.07 bar | 9. 2004B-W | Female quick-connect – white |
| 2. 2-2003-7040A | Control solenoid assembly | 10. 2024-160 | 1/4" OD x .160" ID tubing |
| 3. 2-2003-7040B | Nozzle air solenoid assembly | 11. 2081A | Air input quick-connect |
| 4. 2-2006DB-VC | Display PCB assembly | 12. 2085 | 1/8 NPT x 1/4 barb – low profile |
| 5. 2-2006PS-VC | Power supply PCB assembly | 13. 2086 | 1/8 NPT x 1/4 barb 90° – brass |
| 6. 2-2017-1500 | Foot pedal
receptacle assembly | 14. 2087 | 1/8 NPT x 1/4 barb elbow – brass |
| 7. 2001A | Gauge 0 to 30 psi,
0 to 2.07 bar | 15. 2088 | Fitting
1/8 NPT x 1/4 barb – brass |
| 8. 2004B | Female quick-connect – black
(hidden from view
- below item #9) | 16. 7108 | Exhaust muffler |
| | | 17. 7109 | Power switch |
| | | 18. 7111 | Fuse – .125A |
| | | 19. 7143-01 | Output circuit fuse |

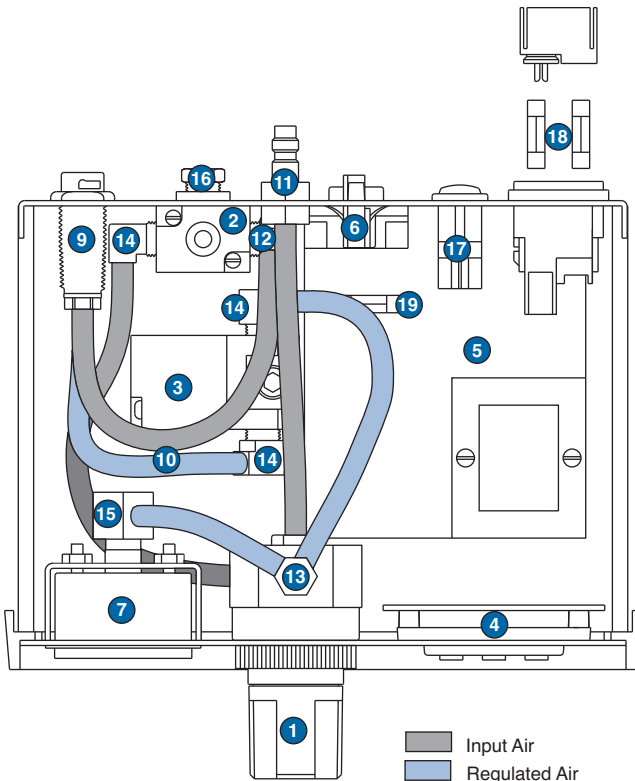

Troubleshooting Guide

Trouble	Possible cause and correction
No power	Be sure that there is power at the wall receptacle. Check the input power fuse. If the fuse has blown, check the voltage value in the fuse cartridge window. Be sure that it matches the input voltage.
End-of-cycle feedback circuit is not functioning	Ensure that the external voltage to the circuit is between 5 and 24 VDC and that the load does not exceed 250mA. If the circuit has been overloaded, the fuse may have blown. Replace fuse, if necessary.
Valve does not spray below .015 second time setting	Response delay in pneumatic circuit does not allow the valve to open when time is at or below 0.015 seconds. Increase time.
Inconsistent deposits	Valve operating pressure lower than 60 psi (4.1 bar) can cause inconsistent output. Make sure pressure is set at 70 psi (4.8 bar). Check controller and reservoir air pressure readings to be sure air pressure is not varying. Air bubbles in the material can cause inconsistency. For best results, remove all air bubbles.
Timer seems inoperative.	Check to be sure time override mode is off.

If trouble cannot be corrected, or if you need further assistance, **please call us**. In the US, call 800-556-3484. In the UK, phone 0800 585733. In Asia, +86 (21) 3866 9166.

Input/Output Connections

1. Voltage Initiate Circuit

The controller may be initiated with a 5 to 24 VDC signal across pins 1 and 2. The signal can be momentary (no less than 0.02 seconds) or maintained. A new cycle will begin once power is removed and then applied again.

2. End-of-Cycle Feedback Circuit

Upon completion of a dispense cycle, an open collector circuit closes and remains closed until the next dispense cycle. This circuit can be utilized to signal back to a host computer, start another device in sequence or other operations that need to be tied into completion of the dispense cycle.

Upon closure, power from an external 5 to 24 VDC source is allowed to pass through the circuit to operate a load. The load illustrated is a relay, but this could be any device that will operate within the 5 to 24 volt range. Power consumption of the load must not exceed 250mA.

3. Mechanical Contact Initiate

The controller can be initiated via the closure of mechanical contacts such as a relay or switch using pins 5 and 7. Closure of the contacts can be momentary (no less than 0.02 seconds) or maintained. A new cycle will begin once the contacts are opened and then closed again.

Note: For applications using more than one 7040, see page 15 for connection instructions.

I/O Connection

The 9-pin D connector and internal circuitry provide external initiate and end-of-cycle feedback signal. The pin connections are shown below.

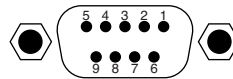

Pin	Function
1.	Initiate +
2.	Initiate -
3.	Output +
4.	Output -
5.	Contact Closure
6.	Chassis Ground
7.	Contact Closure
8.	Not Used
9.	Not Used

Note: 9-pin male connector assembly is included (replacement part # 7154).

Input/Output Connections

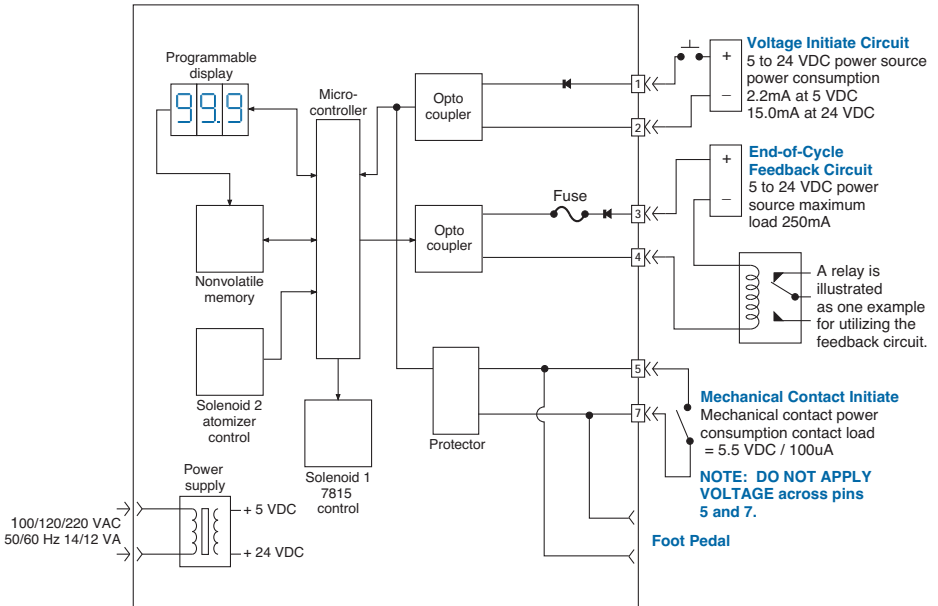

Connecting more than one 7040 Controller

1. Voltage Initiate Circuit

To start the dispense cycle for multiple 7040 controllers at the same time, connect the voltage initiate circuit in parallel as illustrated.

Note: The amperage consumption for the voltage initiate circuit will increase with each controller that is connected. The initiate power supply should be sized accordingly.

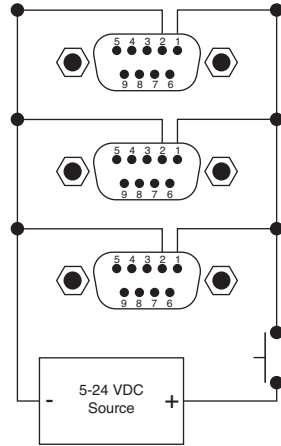

1. Parallel circuit diagram for Voltage Initiate.

2. End-of-Cycle Feedback Circuit

This circuit will ensure that the end-of-cycle signal will come from the last 7040 to complete a dispense cycle. Connect in series as illustrated.

Note: There will be a maximum voltage drop of 2.0 VDC through the feedback circuit with each 7040 that is added to the series. The input power should be adjusted for this drop to ensure that the required voltage is available to operate the load. Maximum input voltage to terminals 3 and 4 must not exceed 30.0 VDC.

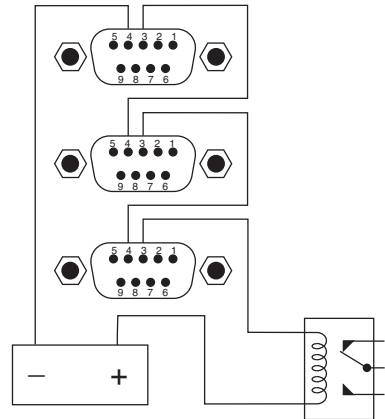

2. Series circuit for End-of-Cycle Feedback feature. A relay is illustrated as one example for utilizing the feedback circuit.



**For EFD sales and service in over 30 countries,
contact EFD or go to www.efd-inc.com**

EFD, Inc.

East Providence, RI USA

USA & Canada: 800-556-3484; +1-401-431-7000

info@efd-inc.com

www.efd-inc.com

EFD International Inc.

Dunstable, Bedfordshire, UK

0800 585733 or +44 (0) 1582 666334

Ireland 00800 8272 9444

europa@efd-inc.com

www.efd-inc.com

EFD, Inc., Asia

China: +86 (21) 3866 9166

china@efd-inc.com

www.efd-inc.com/cn

Singapore: +65 6896 9630

sin-mal@efd-inc.com

The Wave Design is a trademark of Nordson Corporation
©2008 Nordson Corporation 7040-MAN-01 v122208



This equipment is regulated by the European Union under WEEE
Directive (2002/96/EC). See www.efd-inc.com for information about
how to properly dispose of this equipment.