

# MicroCoat® System Operating Manual

---

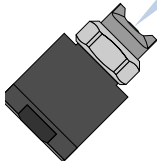

## MC2000 Series

MC785, MC785-WF Spray Valves



US: 800-498-8865

UK: 0800 585733

Mexico: 001-800-556-3484

# Introduction

The MicroCoat® System provides precise lubrication control for metal stamping operations.

The MC2000 series systems and MC785 series spray valves are all produced to exacting specifications and thoroughly tested prior to shipment.

The MC785 series valves are designed for long life without maintenance when clean lubricant is used.

To obtain the maximum performance from your MicroCoat® System, please read through these instructions carefully.

Our goal is to build not only the finest equipment but also to build long-term customer relationships founded on superb quality, service, value and trust.

**If you have any questions,  
please contact us for assistance.**

.....  
US 800-498-8865

UK 0800 585733

Mexico 001-800-556-3484

Fax 401-431-0237

# Contents

Specifications .....	4
How the System Operates .....	5
System Features .....	6-7
System Assembly .....	8-13
Step 1: Set Up the Controller.....	8
Step 2: Connect the Press Air Solenoid .....	8-9
Step 3: Connect the Emergency Stop Circuit .....	10
Step 4: Mount the Spray Valves.....	11
Step 5: Connect the Valve Hoses .....	12
System Setup Diagram.....	13
System Setup .....	14-15
Fill the Tank Reservoir.....	14
Prime the System.....	14
Adjust the Spray .....	15
Preventive Maintenance.....	15
Spray Valve Maintenance.....	16
Spray Valve Exploded View & Part Numbers.....	17
Controller Air Schematic .....	18
Controller and Tank Replacement Part Numbers .....	19
Troubleshooting Guide.....	20
Accessories .....	21
Warranty .....	back cover

# Specifications

## MC785 & MC785-WF Valves

Size (with fittings): 2.61" (66.29 mm) length  
1.94" (49.28 mm) width

Weight: 7.28 oz (206 gr)

Lubricant chamber: Hard-coated aluminum

Return spring: Type 303 stainless steel

Needle and nozzle: Type 303 stainless steel

Air cap: Type 303 stainless steel

Diaphragm: Viton® with Teflon® coating

Lubricant inlet hole: 1/8 NPT

Mounting: 1/4-28 UNF tapped hole

Operating frequency: Up to 60 per minute

Nozzle diameter: 0.046" (1.17 mm)

U.S. Patent # D-398, 705

## MC2000-SYS and MC2002-SYS

MC2000-SYS: W 10.5" x D 11.13" x H 14.0"  
(W 26.7 cm x D 28.3 cm x H 35.6 cm)

MC2002-SYS: W 10.5" x D 11.13" x H 20.5"  
(W 26.7 cm x D 28.3 cm x H 52.1 cm)

Net weight: MC2000-SYS: 22.7 lb (10.3 kg)  
MC2002-SYS: 24.8 lb (11.2 kg)

Air input required: 60 psi (4.14 bar) minimum

System operating pressure: 30 psi (2.07 bar) maximum

Tank air pressure regulator: 30 psi (2.07 bar) maximum

Nozzle air pressure regulator: 30 psi (2.07 bar) maximum

Cycle rate: Up to 60 per minute

Pressure switch rating: 20VA 240V

Low level switch rating: 20VA 240V

Tank reservoir safety relief pressure: 40 psi (2.76 bar)

Tank construction: Acrylic tank wall;  
Hard-coated aluminum end caps

Tank capacity: MC2000-SYS: 1 gallon (3.8 L)  
MC2002-SYS: 2 gallons (7.5 L)

## CE Compliant

Satisfies machinery directive 89/392/EEC

As amended by CE marking directive 93/68/EEC

Evaluated to EN983:1996

**Note:** Specifications and technical details are subject to engineering changes without prior notification.

# How the System Operates

The MicroCoat® System incorporates up to two low volume low pressure (LVLP) spray valves, a lubricant reservoir and a controller that regulates air pressure, meters lubricant flow and controls valve operation.

Constant air pressure applied to the tank reservoir forces lubricant through precision fluid flow controls to the valves.

When the press is stamping, a 3-way air solenoid activates the system and opens the valves. As the valve opens, LVLP air creates a pressure drop at the nozzle, causing the lubricant to spray in a fine film onto the stock.

Lubricant flow can be adjusted independently for each valve via flow controls on top of the MC2000 series tank reservoir.

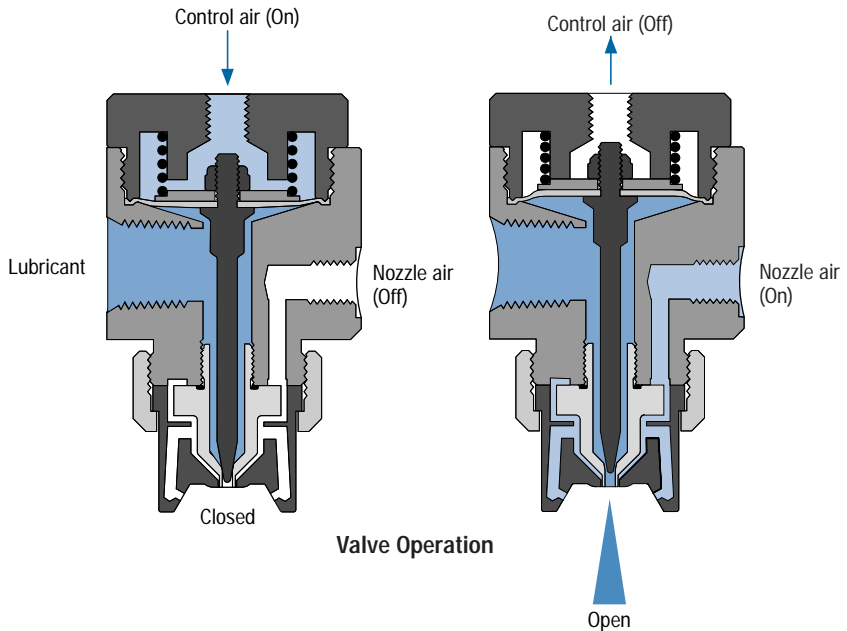

# System Features

## 1. System Switch

Turns the system air supply on and off.

## 2. Mode Switch

Use Manual/Setup position to prime and test the valves without running the press.

In the Auto/Run position, the system will spray lubricant when the press begins stamping.

Press air solenoid must be properly installed to allow the MicroCoat® System to run in Auto/Run mode (refer to page 9).

## 3. Tank Air Pressure

Regulates air pressure in the lubricant reservoir. For most lubricants, 15 psi (1.04 bar) is a good start.

Minimum setting is 12 psi (0.83 bar).

## 4. Nozzle Air

Regulates nozzle air pressure.

Average setting is 8 to 12 psi (0.55 to 0.83 bar). Higher pressure provides finer spray.

## 5. Flow Controls

Provide independent flow control of the lubricant to each spray valve. Each yellow ring on the stem coming out of the middle of the knob indicates one complete revolution.

Turn counterclockwise to increase flow.

## 6. Low Level Switch

Prevents the system from operating without lubricant when connected to the press Emergency Stop Circuit. Switch opens when tank level is near empty.

## 7. Air Pressure Relief Valve

Automatically exhausts air if tank reservoir pressure exceeds 40 psi (2.76 bar).

Also used to manually exhaust air pressure before refilling tank.

## 8. Fill Port Cap

Ported threads relieve any residual reservoir air pressure when cap is loosened.

## 9. Drain Plug

## 10. Fluid Dip Tube

Pressurized lubricant flows through this tube to the Flow Controls.

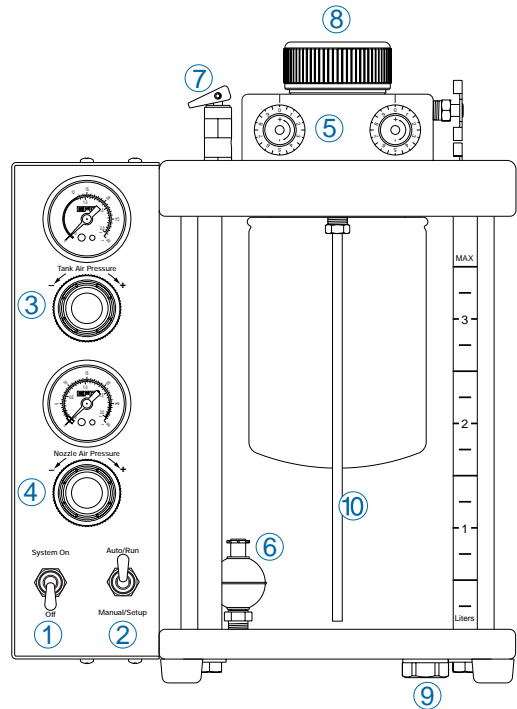

MC2000 Front View

## 11. Fluid Outlet

Pressurized lubricant flows from these ports to the spray valves.

## 12. Bleed Valve

Two valve locations release air after filter replacement.

## 13. Lubricant Inline Filter

## 14. Nozzle Air

Air from these ports is used to spray the lubricant.

## 15. Valve Control Air

Air from these ports controls the opening and closing of the spray valves.

## 16. Two-pin Connector

Connects the low level and low pressure switches to the press.

**Must be wired to the press Emergency Stop Circuit to prevent the press from operating without lubricant (page 10).**

## 17. Constant Air Input

The main air supply to the system should be a minimum of 60 psi (4.14 bar).

## 18. Control Air Input from Solenoid

Activates the system when the press begins stamping. Minimum 60 psi (4.14 bar) required.

## 19. Pilot Valve Exhaust Muffler

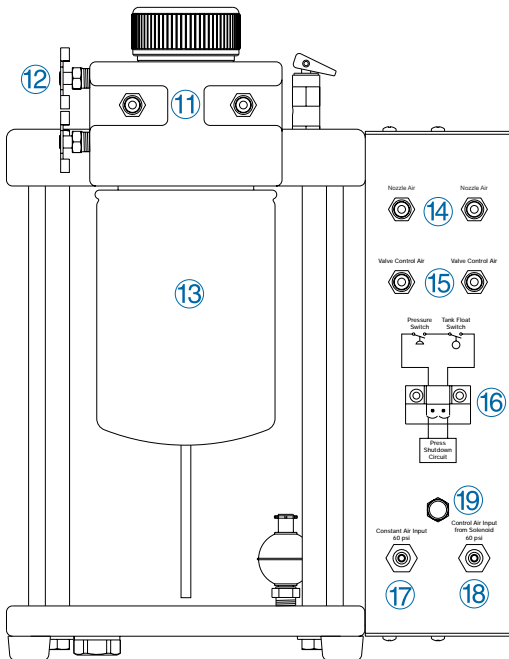

MC2000 Rear View

# System Assembly

## Step 1: Set Up the Controller

First, place the controller and tank reservoir away from traffic areas and position the tank to allow for convenient refilling.

The controller requires two 60 psi (4.14 bar) filtered, dry air inputs:

- I. Constant air
- II. Control air from a 3-way solenoid

Refer to diagram on page 9.

1. Set the controller System Pressure switch to the Off position and the mode switch to the Auto/Run position.
2. Connect the five-micron filter regulator to the plant air supply.
3. Using the two black air hoses provided with the system, connect the air hose quick-connects to the Constant Air Input and Control Air Input from Solenoid fittings at the back of the controller.

## Step 2: Connect the Press Air Solenoid

To provide proper air distribution and control, a press air solenoid (available separately) must be connected to the MicroCoat® control air input.

1. Select the appropriate 3-way solenoid. Flow must meet or exceed 2.0 cfm (.06 cu. m.) at 60 psi (4.14 bar).
2. Cut the control air hose at a convenient location and install the solenoid as shown.
3. Connect the solenoid wires to the press control circuit.

**Note:** When the press is stamping, the solenoid allows control air into the MicroCoat® System. When the press is idle, the solenoid shuts off the air pressure and prevents the MicroCoat® System from operating.

## Press Air Solenoid Diagram

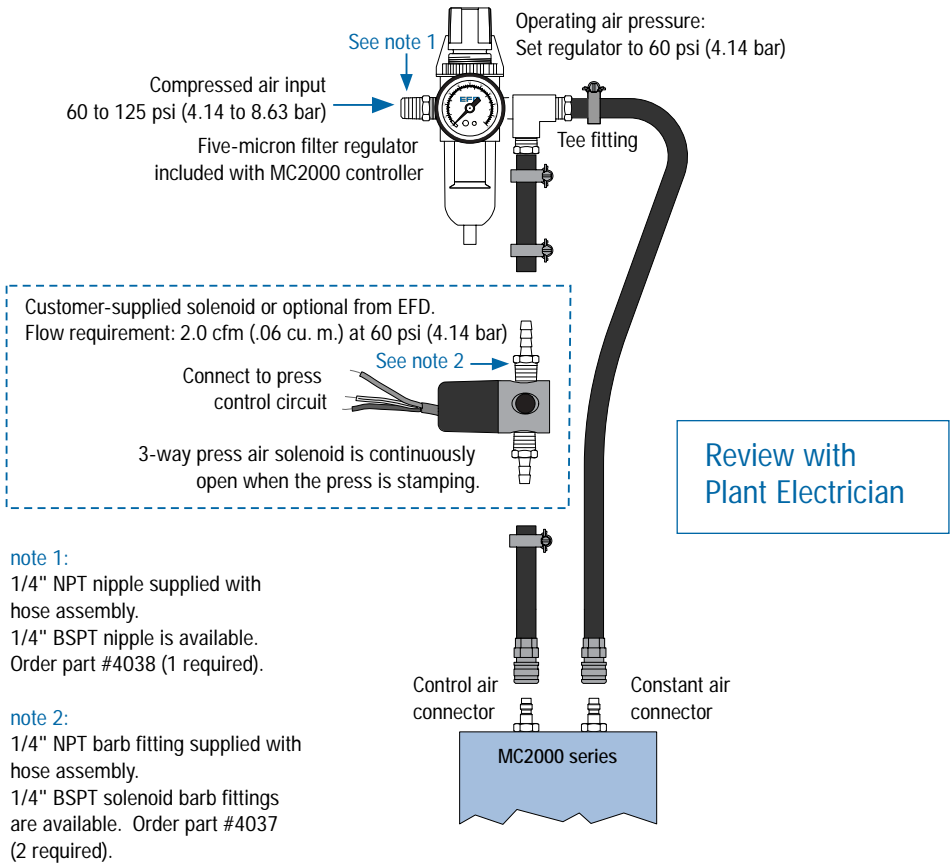

### EFD MicroCoat Solenoids

Part Number	Description
2003MC-24DC	24 volt DC solenoid
2003MC-24AC	24 volt AC solenoid
2003MC-100	100 volt AC solenoid
2003MC-120	120 volt AC solenoid
2003MC-220	220 volt AC solenoid

### EFD MicroCoat Solenoid Cord Sets

Part Number	Description
2009MC	AC solenoid cord set
2009MC-24DC	DC solenoid cord set

## Step 3: Connect the Emergency Stop Circuit

The Emergency Stop Circuit on the press must be properly wired to the MicroCoat® System to prevent the press from stamping without lubricant and to alert the operator if the tank air pressure drops below 10 psi (0.69 bar).

The two safety switches—the low level switch and the low pressure switch—are already wired in series with each other.

These switches must also be wired in series with the Emergency Stop Circuit from the press.

Connect the red and black wire to the Emergency Stop Circuit located on the press.

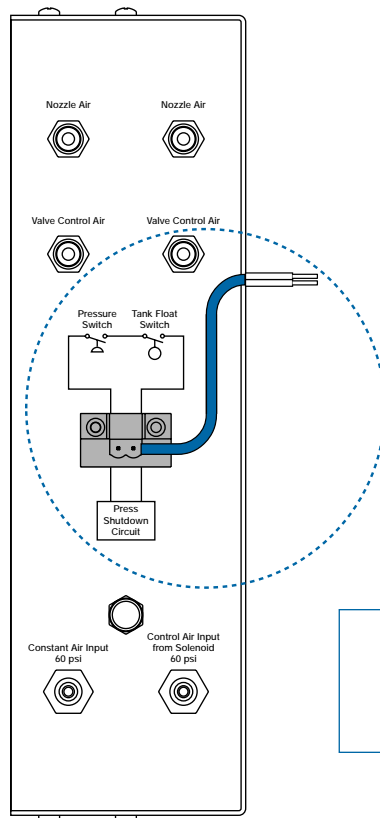

Review with  
Plant Electrician

## Step 4: Mount the Spray Valves

Mount each valve with the mounting clamp (#78530) provided, or use the 1/4-28 mounting hole in the valve body to attach the valve to an alternative mounting bracket.

**Note:** Optional valve mounting fixtures provide easy installation of the valves without the need to drill or fabricate attachment hardware. See page 21 for further information.

To ensure proper lubricant coverage, mount the MC785 valve so the tabs on the air cap are in line with the stock as illustrated. Use the valve alignment tool (#MC7326) shown on page 21 for precise valve alignment.

**IMPORTANT:** If you loosen the air cap retainer nut to reposition the tabs, be sure to retighten the nut with a wrench before operating the valve.

The width of spray coverage is determined by the distance between the valve nozzle and the stock, as shown in the chart below.

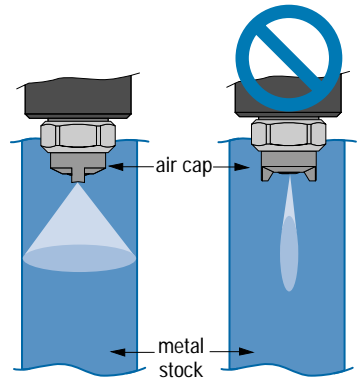

Proper air cap alignment

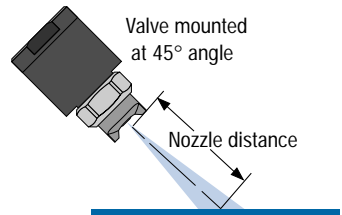
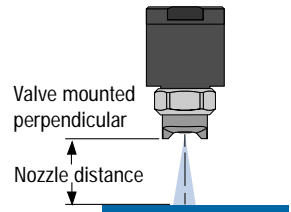

### Spray Area Coverage

	Nozzle distance to stock					
Spray valves	1.00" 25.4 mm	2.00" 50.8 mm	3.00" 76.2 mm	4.00" 101.6 mm	5.00" 127.0 mm	6.00" 152.4 mm
<b>MC785</b>	1.00" 25.4 mm	1.50" 38.1 mm	2.00" 50.8 mm	2.50" 63.5 mm	2.75" 69.9 mm	3.25" 82.6 mm
<b>MC785-WF</b>	1.50" 38.1 mm	2.50" 63.5 mm	3.50" 88.9 mm	4.50" 114.3 mm	5.50" 139.7 mm	6.50" 165.1 mm

The MC785-WF is recommended for spray widths from 2.0" to 6.0".

Note: Spray width coverage may vary depending on the viscosity and surface tension of the fluid.

## Step 5: Connect the Valve Hoses

Each valve is supplied with a tri-hose assembly and a series of numbered tags. The numbered tags are used to ensure that each valve is connected to the corresponding outlets on the back of the system.

Connect each valve as follows:

1. First note each valve's position and then assign numbers by valve location. Place the corresponding number tag on both ends of the tubing jacket.
2. Connect the clear fluid hose into the appropriate Fluid Outlet connector on the back of the tank.
3. Connect the black air hose to the corresponding black Nozzle Air connector on the back of the controller.
4. Connect the white air hose to the corresponding white Valve Control Air connector on the back of the controller.
5. Repeat the above for the second valve.

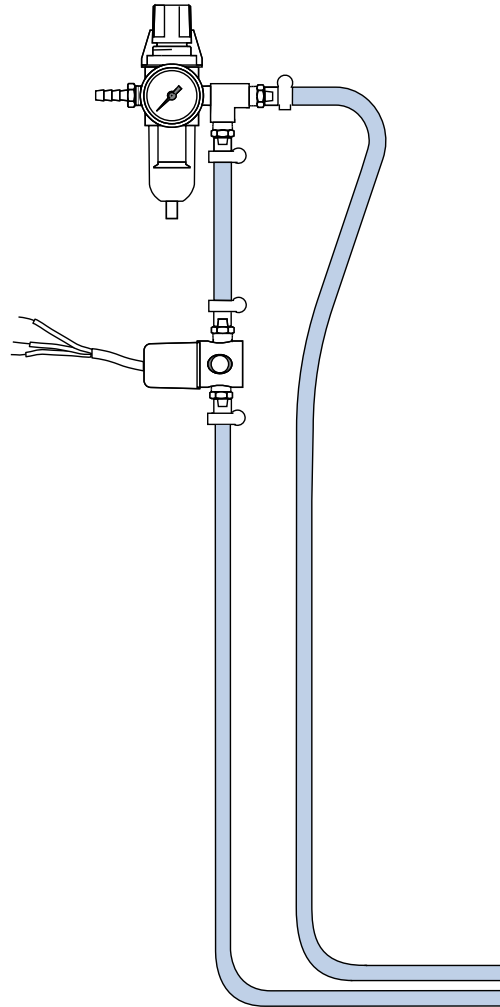

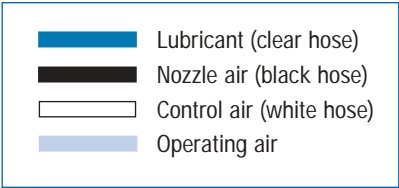

**Note:** Replace the filter element (part #4000FLT) every 6 months or 1000 hours of operation.

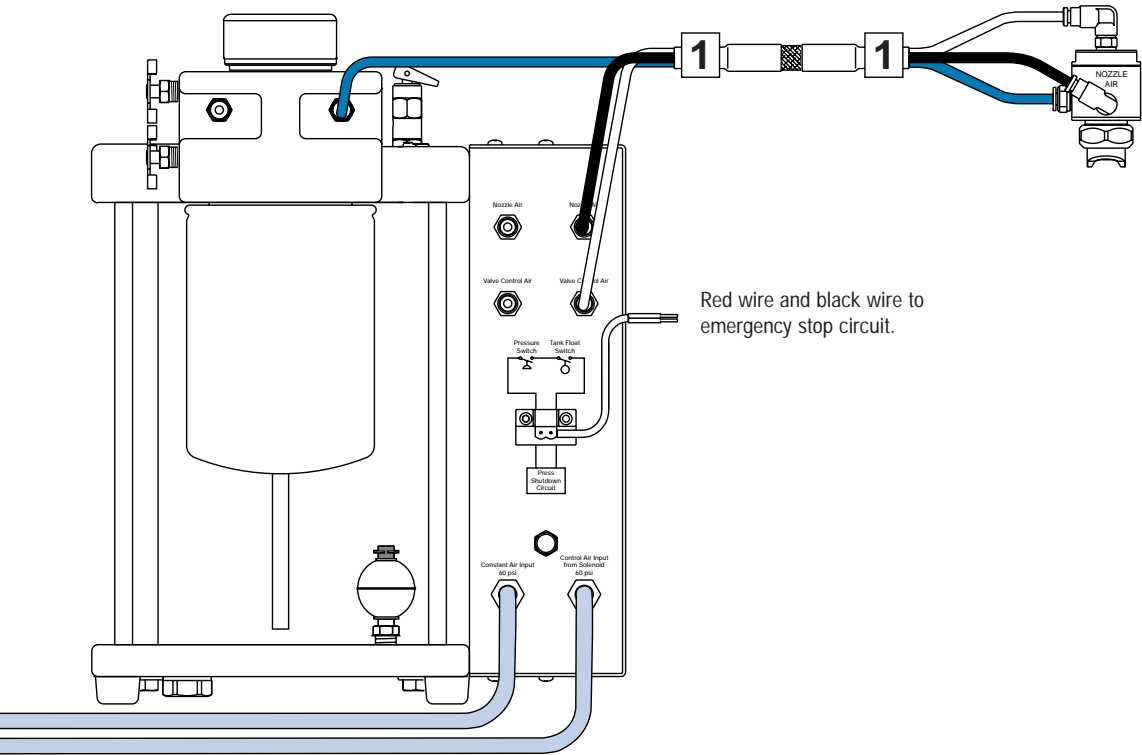

Red wire and black wire to emergency stop circuit.

# System Setup

## Check All Connections

1. Check that all connections are correct and secure.
2. Verify that the System Pressure switch is set to the Off position and the mode switch is set to the Auto/Run position.
3. Check that the input air supply is connected and set at 60 psi (4.14 bar).

## Fill the Tank Reservoir

1. Unscrew the tank cap and fill the tank reservoir with lubricant to the level indicated on the tank label.

**Note:** Do not overfill. Overfilling may cause lubricant to flow back into the controller.

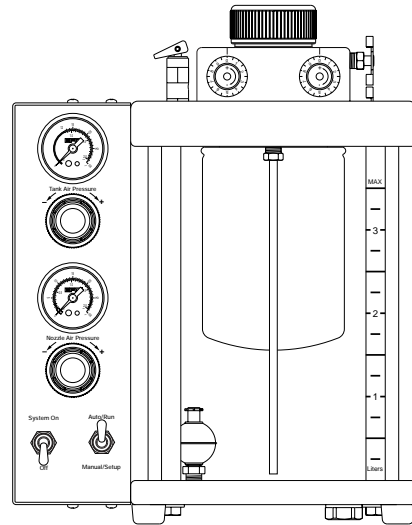

**Note:** Regulator knobs have a push-to-lock, pull-to-unlock feature.

## Prime the System

1. Set the System Pressure switch to On.
2. Adjust the Tank Air Pressure regulator to 15 psi (1.04 bar). Do not set pressure lower than 12 psi (0.83 bar).
3. Turn the Nozzle Air pressure regulator knob counterclockwise as far as it will go to prevent nozzle air from flowing while priming the valves.
4. Turn both Flow Control knobs clockwise until completely closed.
5. Set the mode switch to Manual/Setup.
6. First, open the bleed valve located above the filter until all the air is removed. Close the bleed valve, then open the second bleed valve located next to flow controls until all air is removed. Close the bleed valve.
7. Select one valve and open the appropriate Flow Control knob about five (5) full turns (counterclockwise) to fill the hose and prime the valve.
8. When the lubricant flows in a steady stream, the valve is primed. Close the Flow Control (turn clockwise).
9. Repeat steps 7 and 8 for second valve.

## Adjust the Spray

1. As a starting point, select one valve and adjust the Flow Control knob so that lubricant flows from the valve at the rate of approximately one drop per second.
2. Note the number set on the graduated dial of the open Flow Control. Set the flow for the second valve to the same setting.
3. Turn the Nozzle Air regulator clockwise until pressure reads between 8 to 10 psi (0.55 to 0.69 bar) and the valve begins to spray. Thicker lubricants may require 12 to 15 psi (0.83 to 1.04 bar). Push the knob in to lock.
4. Set the mode switch to Auto/Run. The spray will shut off. The valves are ready to spray when the press is stamping.
5. After starting the press, adjust the Flow Control knobs as needed to provide proper lubricant coverage.

---

**IMPORTANT:** Each valve must be fully primed (lubricant flows in a steady stream) before adjusting the spray.

---

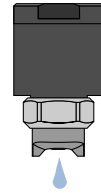

---

After priming the valve, adjust lubricant flow to a rate of approximately one drop per second.

---

## Preventive Maintenance

The MicroCoat® System is designed for long life with minimal maintenance. To ensure trouble-free performance, follow these precautions and preventive maintenance steps:

1. Always use clean lubricant.
2. Check for residue at the bottom of the tank reservoir and clean if necessary.
3. Do not clean the tank with chlorinated solvents, aromatic hydrocarbons or any fluid that will attack acrylics. Use only soap and water or mineral spirits to clean acrylic tank surfaces.
4. Operate the system with clean, dry, oil-free air. Drain the bowl on the five-micron filter regulator whenever moisture or oil is present.
5. Replace the lubricant filter (Part #4000FLT) every 6 months or 1000 hours of operation.

---

**Caution:** Before performing any maintenance, set the **System Pressure Switch** to the **Off** position and depressurize the tank reservoir by lifting the lever on the tank pressure relief valve.

---

# Spray Valve Maintenance

---

**Caution:** Before performing any maintenance, set the **System Pressure Switch** to the **Off** position and depressurize the tank reservoir by lifting the lever on the tank pressure relief valve.

---

When using filtered plant air and clean lubricants, the MC785 series spray valves are designed for long-term performance without scheduled maintenance.

If lubricant flow stops or becomes erratic, first review Trouble-shooting on page 20. Cleaning the nozzle will solve most problems related to lubricant flow and spray patterns.

## To Clean the Nozzle

Remove the air cap retainer nut, air cap and nozzle from the outlet end of the valve. Clean and reinstall, as illustrated on page 11.

## Valve Disassembly

**Note:** Install a new diaphragm (#78527) each time the valve is reassembled.

1. Remove the air cap retainer nut, air cap and nozzle from the outlet end of the valve.
2. Remove the diaphragm chamber cap, diaphragm return spring and needle/diaphragm assembly from the valve body.
3. Remove the diaphragm retaining nut and spring locating washer from the needle, then remove and discard the old diaphragm.
4. Clean all parts in mineral spirits.

## Valve Reassembly

1. Place the new diaphragm over the threaded end of the needle. The black Viton® side of the diaphragm should face the threaded end. The blue-grey Teflon® side should face the wetted side of the valve (illustration on page 17).
2. Place the spring locating washer over the threaded end of the needle. The stepped side should face the threaded end.
3. Install a new diaphragm retaining nut (included with #78527 diaphragm) and turn it until the nut starts to feel tight and the diaphragm cannot be rotated on the needle with fingers. Avoid crushing the diaphragm causing it to bulge away from the washer.
4. Install the needle/diaphragm assembly into the valve body, then install the diaphragm return spring and diaphragm chamber cap, and tighten firmly.
5. Reinstall the nozzle, air cap and air cap retainer, as illustrated on page 11.

The air cap retainer nut should be tightened with a wrench to prevent loosening due to press vibration.

## MC785 Series Spray Valve Part Numbers

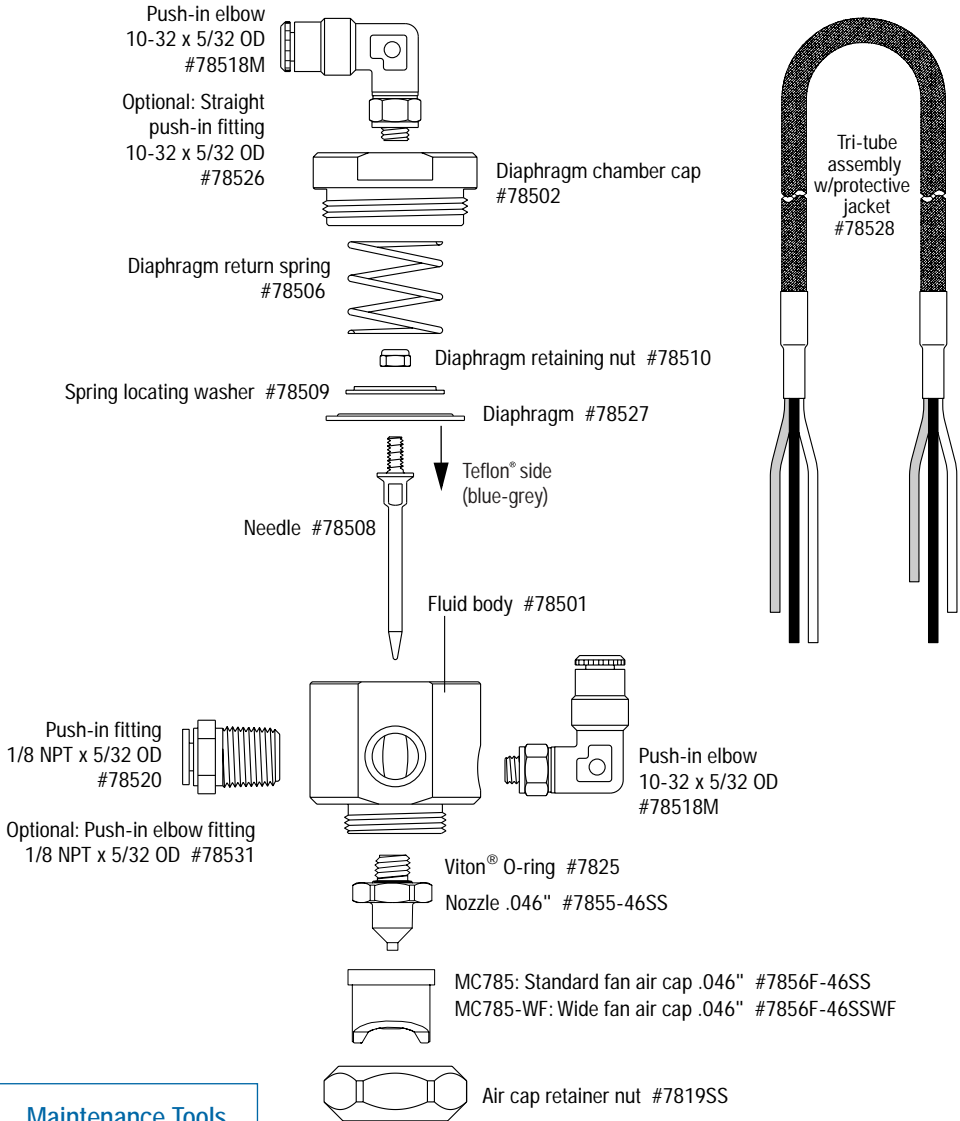



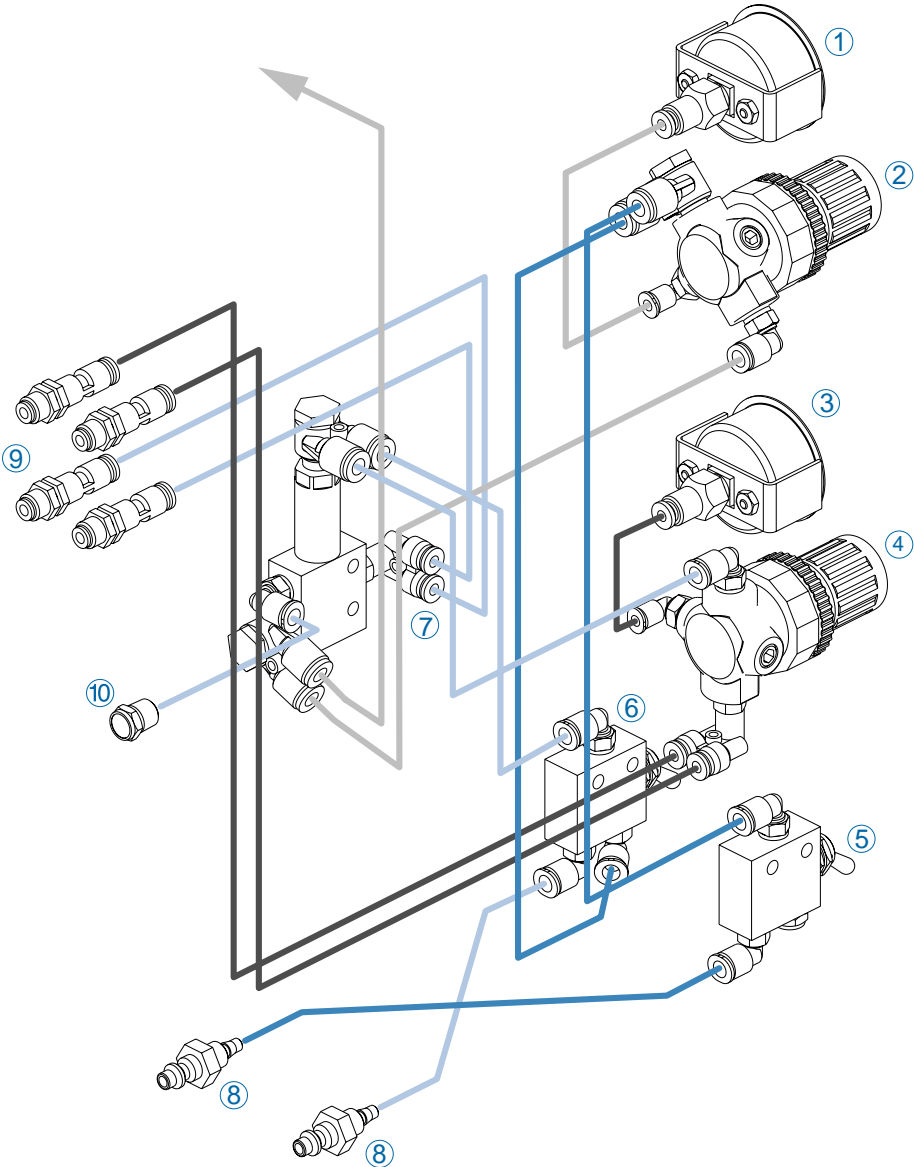

**Maintenance Tools**

- 8" adjustable wrench
- 7/8" open end wrench
- 5/16" box end wrench
- 1/4" nut driver

# Controller Air Schematic



	Constant air input (40 psi / 2.76 bar minimum)
	Tank air pressure
	Nozzle air
	Control air from solenoid (40 psi / 2.76 bar minimum)

# System Replacement Part Numbers

## Components for the MicroCoat System (Refer to schematic on page 18.)

1. 2001MC System pressure gauge 0 to 30 psi (0 to 2.07 bar)
2. 2001MC2A System pressure regulator 0 to 30 psi (0 to 2.07 bar)
3. 2001MCA Nozzle air gauge
4. 2001MC2B Nozzle air pressure regulator
5. 4044A System On-Off switch assembly
6. 4044B Manual/Auto Run switch assembly
7. 4045 Air Pilot Valve assembly
8. 2081A Male air inlet fittings
9. 4042 Air outlet push-in fittings to valves
10. 7108 Pilot valve exhaust muffler

### Items not shown

- 4029 Fluid pressure switch
- 2024-6mm Clear polyurethane 6mm OD x 4mm ID tubing
- 2024L Clear polyurethane 5/32" OD x 3/32" ID tubing
- 7114G Male connector for the press shutdown circuit

## Fluid Tank Components

- 68808 Fluid outlet compression fittings to valves
- 2176MC Flow control with knob
- 2176C-KNOB Flow control knob
- 68517 Tank Filler cap
- 68506 (2) Neoprene gaskets
- 68503 Acrylic tube 6.5" D x 8.96" L (one gallon)
- 68514 Acrylic tube 6.5" D x 16.35" L (two gallon)
- 68511 Nickel-plated brass drain plug
- 68509 Pressure relief valve 40 psi (2.76 bar)
- 68816 Stainless steel float switch kit

# Troubleshooting Guide

## MC2000 System

### Possible cause and correction

---

Air pressure regulator will not maintain set pressure.	Contaminated air supply. Remove the controller cover to access the regulator. Remove the brass hex plug, spring and poppet from the regulator. Clean poppet and reinstall the poppet, spring and plug.
No lubricant flow to valve.	Tank pressure may be too low. <b>Minimum</b> operating tank air pressure is 12 psi (0.83 bar).

---

## MC785, MC785-WF Spray Valve

### Possible cause and correction

---

Lubricant flows but valve does not spray.	Air cap may be clogged. Be sure oil tank filter is clean. Remove air cap and clean the inside of the air cap and the outside of the nozzle. Refer to Valve Maintenance on page 16.  Nozzle air pressure regulator may be set too low. Increase pressure as needed. Normal working range is within 8 to 15 psi (0.55 to 1.03 bar).
Valve drips after shutdown.	Dripping can be caused by improper seating of the needle in the nozzle. Clean the needle and nozzle, and replace any worn or damaged parts.  Ensure nozzle is tight to seat the needle properly.

---

If trouble cannot be corrected, or if you need further assistance, **please call us**. In the U.S., **800-498-8865**. In the U.K., ring free 0800 585733. In Mexico, 001-800-556-3484.

# Accessories

## Valve Mounting Clamp

#78530: Use to mount MC785 series valve or to secure mounting rod on press. Included with each MC785 and MC785-WF valve.

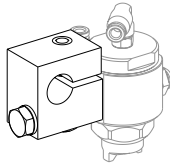

## Cross Clamp

#MC7321: Used to extend valves from expansion or gantry mount.

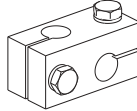

## Expansion Mount

#MC7325: Fits in the press window of four post stamping presses. Includes (2) sets of 1/2" diameter stainless steel rods and mounting hardware. Works with press windows up to 12".

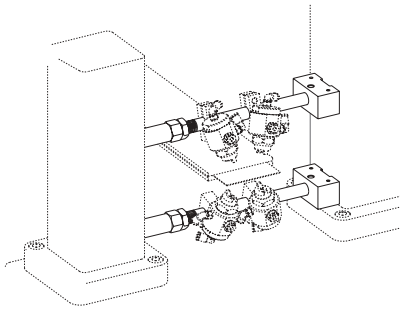

## Stand

#MC7331: Aluminum stand for the one gallon system (MC2000-SYS). Comes complete with all items necessary for mounting. Height 30". Width 20".

#MC7332: Aluminum stand for the two gallon system (MC2002-SYS). Comes complete with all items necessary for mounting. Height 21". Width 20".

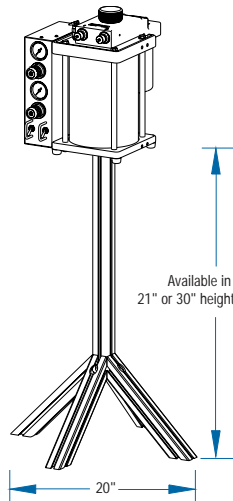

## Mounting Brackets

#MC7302: For mounting MC2000 series system to press enclosure. Included with MC2000 series systems.

## Mounting Rod

#7312: Stainless steel rod 1/2" diameter x 10" long.



## Extension Rod

#MC7327: Use with cross clamp to extend valves beyond press window. Rod is 1/2" diameter x 4" long.



## Gantry Mount

#MC7328: For installing on bolster plate or other flat area. Includes (4) MC7321 cross clamps, (2) 9.4" threaded vertical rods, (2) 15.75 horizontal rods and (1) 13.75" base plate.

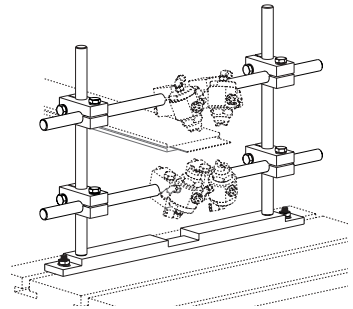

## Valve Alignment Tool

#MC7326: Use to position the valve to provide exact spray coverage. Includes (3) standard and (3) wide fan templates.

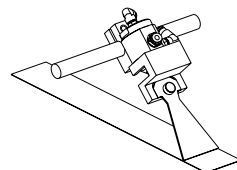

## EFD ONE YEAR LIMITED WARRANTY

All components of the EFD MicroCoat System are warranted for one year from date of purchase to be free from defects in material and workmanship (but not against damage caused by misuse, abrasion, corrosion, negligence, accident, faulty installation or by dispensing material incompatible with equipment) when the equipment is installed and operated in accordance with factory recommendations and instructions. EFD will repair or replace free of charge any part of the equipment thus found to be defective, on authorized return of the part prepaid to our factory during the warranty period. For the spray valve, the only exceptions are those parts which normally wear and must be replaced routinely such as, but not limited to, needles, diaphragms and nozzles.

In no event shall any liability or obligation of EFD arising from this warranty exceed the purchase price of the equipment. This warranty is valid only when oil-free, clean, dry, filtered air is used.

EFD makes no warranty of merchantability or fitness for a particular purpose. In no event shall EFD be liable for incidental or consequential damages.



977 Waterman Avenue, East Providence, Rhode Island 02914-1342 USA  
US toll free: 800-498-8865 Telephone: 401-434-1680  
Mexico: 001-800-556-3484 Fax: 401-431-0237 [www.efd-microcoat.com](http://www.efd-microcoat.com)  
E-mail: [microcoat@efd-inc.com](mailto:microcoat@efd-inc.com)

Unit 14, Apex Business Centre, Boscombe Road, Dunstable, Bedfordshire LU5 4SB UK  
Freephone: 0800 585733 Telephone: 01582 666334 Fax: 01582 664227  
E-mail: [uk@efd-inc.com](mailto:uk@efd-inc.com) Ireland 00800 8272 9444

Sales and service of the EFD MicroCoat System is available through EFD authorized distributors in over 30 countries. Please contact EFD U.S.A. for specific names and addresses.