

Valve Disassembly and Reassembly Procedures

CAUTION: To prevent damage, the valve must be disassembled starting at the fluid outlet end of the valve.

Valve maintenance

To thoroughly clean the fluid body and replace needle packings:

1. Remove needle stroke control knob and spring.
2. Remove air cap retainer, then air cap, nozzle and fittings.
3. Remove fluid body from air cylinder body using a .11" hex wrench, then remove O-ring.
4. Clean fluid body, air cap and nozzle in appropriate solvent.

5. Use extraction tool #7021552 to remove needle packings from fluid body.
6. Remove any remaining packings and spring from needle.

Note: Before reassembling, clean fluid body, air cap and nozzle in appropriate solvent and replace O-ring. Clean needle with cloth dampened in solvent.

Reassemble the valve in reverse order of disassembly. Ensure that the small O-ring and washer on the bottom of the air cylinder body are back in place before reinstalling the packing spring. Lubricate parts indicated with Nye Lubricant #865 included in the Maintenance Kit.

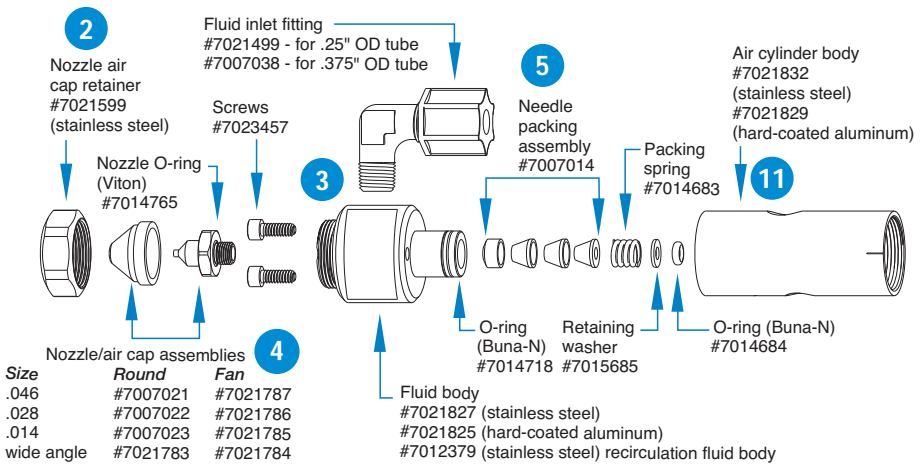

Replacing piston and needle assembly or piston O-ring

7. Remove needle stroke control knob.
8. Remove piston return spring and thrust washers.
9. Remove the snap ring.
10. With small pliers on the spring pilot, pull the piston and needle assembly out of air cylinder. The piston and needle assembly is one unit and cannot be disassembled.
11. Clean the air cylinder body wall, replace piston O-ring and apply lubricant.

Reassemble the valve in reverse order of disassembly. Lubricate

parts indicated with Nye Lubricant #865 (#7023234) included in the Maintenance Kit.

Reseating the needle and nozzle assembly

12. Rotate the stroke adjustment knob clockwise to the closed position.
13. To compress the needle into the nozzle, further rotate the stroke adjustment clockwise one additional reference mark.
14. Return stroke adjustment to normal setting and cycle the valve. If a slight leak remains, repeat steps 1 and 2.
15. If the leak persists, replace the nozzle.

Maintenance Kit

#7021610

Includes all air cylinder and fluid body O-rings, needle packings and lubricant.

Tools required:

- 6" adjustable wrench
- 1/8" hex wrench
- 7/64" hex wrench
- .035 hex wrench
- snap-ring pliers
- packing extraction tool (#7021552)

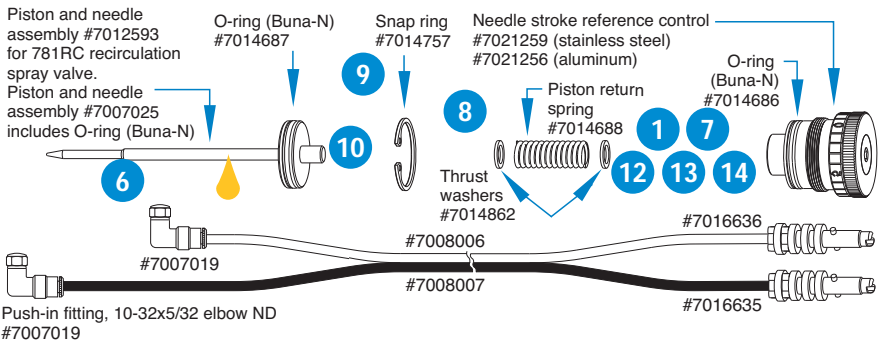

Troubleshooting Guide

No fluid flow

- If valve operating air pressure is too low, the valve will not open. Increase air pressure to 70 psi (4.8 bar) minimum.
- The reservoir air pressure may not be high enough. Increase pressure.
- The nozzle may be clogged. Clean the nozzle.
- The stroke adjustment may be closed. Open stroke adjustment.
- The control and nozzle air lines may be reversed. Check for proper connection.

Valve does not provide clean shut-off, leaving build-up on the nozzle

- The needle may be improperly seated in the nozzle seat. Remove the nozzle, clean the needle and nozzle, replace worn or damaged parts.
- Needle packings may be binding due to leakage, preventing the needle from fully closing. Disassemble the valve and replace the packings if there is evidence of leakage.

Fluid flows from the nozzle but will not spray

- Nozzle air pressure may be too low. Increase air pressure.
- The air passageway between the nozzle and air cylinder cap may be obstructed. Remove the air cylinder cap, and clean the air cylinder cap and nozzle.
- If the fluid viscosity is too high, it will not atomize. Reduce viscosity.



Asia: +86 (21) 3866 9006

Europe: 0800 585733 or +44 (0) 1582 666334

USA & Canada: 800.556.3484 or +1.401.431.7000

technical@nordsonefd.com www.nordsonefd.com

The Wave Design is a trademark of Nordson Corporation.

©2010 Nordson Corporation 781S-MAINT-01 7021608 v011410