

EFD ONE YEAR LIMITED WARRANTY

All components of the EFD ValveMate 7000 are warranted for one year from date of purchase to be free from defects in material and workmanship (but not against damage caused by misuse, abrasion, corrosion, negligence, accident, faulty installation or by dispensing material incompatible with equipment) when the equipment is installed and operated in accordance with factory recommendations and instructions. EFD will repair or replace free of charge any part of the equipment thus found to be defective, on authorized return of the part prepaid to our factory during the warranty period.

In no event shall any liability or obligation of EFD arising from this warranty exceed the purchase price of the equipment. This warranty is valid only when oil-free, clean, dry, filtered air is used.

EFD makes no warranty of merchantability or fitness for a particular purpose. In no event shall EFD be liable for incidental or consequential damages.

China RoHS Hazardous Material Declaration

Part Name	Toxic or Hazardous Substances and Elements					
	Lead (Pb)	Mercury (Hg)	Cadmium (Cd)	Hexavalent Chromium (Cr6)	Polybrominated Biphenyls (PBB)	Polybrominated Diphenyl Ethers (PBDE)
All brass fittings	X	0	0	0	0	0
<p>0: Indicates that this toxic or hazardous substance contained in all the homogeneous materials for this part, according to EIP-A, EIP-B, EIP-C is below the limit requirement in SJ/T11363-2006.</p> <p>X: Indicates that this toxic or hazardous substance contained in all the homogeneous materials for this part, according to EIP-A, EIP-B, EIP-C is above the limit requirement in SJ/T11363-2006.</p>						

Contents

Warranty.....	inside cover
Introduction	2
Specifications	3
Features and Controls	4-5
Indicator Lamps	6
Typical Setup.....	7
Setup	8-10
Installing the Valve	11
Schematic and Replacement Parts List	12
Troubleshooting.....	13
Input/Output Connection Instructions	14-15
Connecting More than One 7000	16-17

Introduction

The ValveMate 7000 is an EFD dispense valve controller, incorporating programmable dispense time, digital time and air pressure readout, microprocessor interface, small size and universal mounting.

Other features include:

- Push-button time setting input or one-touch time programming.
- Floating decimal, providing dispense time ranges of 0.001 to 9.999 and 00.01 to 99.99 seconds.
- Bright red LED that displays both time setting and dispensing pressure in psi or bar scale.
- Push-button purge feature.
- Low air-pressure alarm and End-of-Cycle feedback signals.

The ValveMate 7000 has been designed with the machine builder and operator in mind. The objectives are to bring dispensing control close to the point of application, and to provide the features necessary to make setup and operation as easy and precise as possible.

The ValveMate is easy to operate. Once you have reviewed the features, you will understand the benefits and the ease of control the ValveMate provides.

As with all EFD products, the ValveMate has been produced to exacting specifications and thoroughly tested prior to shipment.

To obtain maximum performance from this equipment, please read the instructions carefully.

IMPORTANT: The primary control of deposit size is the valve open time. The ValveMate 7000 provides easy access and “on the fly” adjustment of valve open time.

Specifications

The small size and adjustable mounting bracket allow for positioning of the ValveMate close to the point of valve operation and provide convenient access to setup and dispensing adjustment controls.

Digital readout is shown for both dispensing time and air pressure.

“On the fly” time adjustment allows adjustment of valve output while the equipment is running. This feature eliminates the need to shut down parent machinery to change or adjust dispense time settings.

Other features and explanations of controls are detailed in the diagrams on pages 4 and 5.

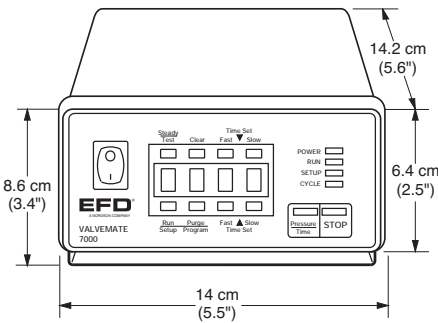

Note: Specifications and technical details are subject to engineering changes without prior notification.

Size:	14 cm W x 14 cm D x 6 cm H (5.5" W x 5.6" D x 2.5" H)
Weight:	1.0 kg (2.3 lb)
Cabinet:	Aluminum
Input Voltage:	Selectable 100/120/220 VAC 50/60 Hz 10/9VA
Internal Voltage:	12 VDC
Feedback Circuits:	5 to 24 VDC NC solid-state switch 250mA maximum
Initiate Circuit:	5 to 24 VDC signal or foot pedal
Air Input:	70 psi (4.8 bar)
Air Consumption:	Approximately 1.5 SCFM at 400 cycles per minute
Cycle Rate:	Exceeds 600 per minute
Time Range:	Programmable 0.001 to 9.999, or 00.01 to 99.99 seconds

Meets CE standards.

Features and Controls

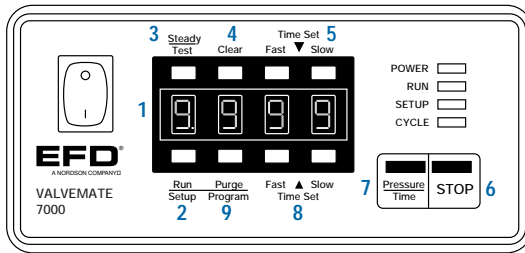

1. Digital time and air pressure LED display

Programmable floating decimal provides time range readout from 0.001 to 99.99 seconds.

Pressure readout can be programmed to read either in psi or bar. (Details on page 10.)

2. RUN / SETUP

Press to change the mode of operation between **RUN** and **SETUP**.

The **SETUP** mode provides access to the **MEMORY**, **CLEAR**, **TEST** and **TIME SET** functions. While in the **SETUP** mode, time values can be changed.

The **RUN** mode locks in the time displayed and locks out access to the **CLEAR** and **TIME SET** functions.

3. STEADY / TEST

In the RUN mode, press this button to place the ValveMate into the **STEADY** mode (no timer) and display will show dashes (---). Press again to return the ValveMate to the timed mode.

In the SETUP mode, this button initiates the ValveMate through one complete cycle. Use to test dispensing before going into the **RUN** mode.

4. CLEAR

In the RUN mode, the function is inoperative.

In the SETUP mode, press to clear time and display to zero.

5. TIME SET ▼ (down)

Use to scroll time display down. Left button scrolls fast. Right button scrolls slowly.

6. STOP

This button, when pressed, stops the 7000 immediately. Also, holding this button in while turning the power switch on will deactivate or reactivate the low air pressure alarm.

7. PRESSURE / TIME

In the RUN mode, press to change the display from time to pressure. Press a second time to change pressure back to time.

In the SETUP mode, press and hold for 3.0 seconds to toggle pressure display from psi to bar. Press a second time for 3.0 seconds to toggle pressure display back to psi.

8. TIME SET ▲ (up)

Use to scroll time display up. Left button scrolls fast. Right button scrolls slowly.

9. PURGE / PROGRAM

The RUN mode opens the valve for as long as the button is held in. Use for priming or purging air from the system.

The SETUP mode opens the valve and sets time for as long as the button is held in. Use for setting deposit amount when a specific time value is not known.

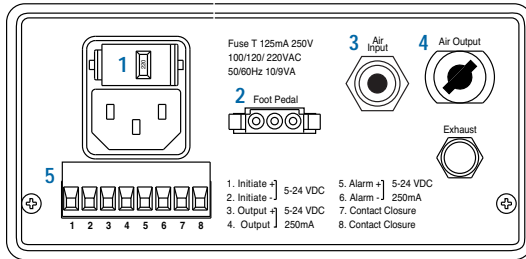

1. Power cord receptacle with voltage selection and fuse cartridge

Three input voltages can be used. 100 VAC, 120 VAC and 220 VAC. To change input voltage, remove fuse cartridge and position the selected voltage marked on the cartridge so that it shows through the window. (Details on page 8.)

2. Foot pedal receptacle

For optional foot pedal, order part #7016714.

3. Air input push-in style fitting

Main air input supply is installed here. Set air pressure at 70 psi (4.8 bar). Lower than 60 psi (4.1 bar) will trigger insufficient air pressure alarm and shut down all functions.

4. Air output quick-connect

Install male connector from EFD valve air input hose here. Push in and turn clockwise to lock.

5. Input / Output terminal strip

For detail connection schematic and instructions for input or output features, see diagram on page 15.

- The 7000 features a low pressure alarm system. An output signal, in the form of a solid-state switch, closes when pressure drops below 60 psi (4.1 bar). This closure can be used to operate an audible alarm, shut-off switch or other device. Maximum load is 250mA from 5 to 24 VDC. In addition, when the air pressure is low, the display will flash between “air” and “pressure” indicating that pressure has dropped below minimum. (See page 4 for instructions on deactivating or reactivating the alarm.)
- An End-of-Cycle signal, also in the form of a solid-state switch, closes upon completion of the dispense cycle. Maximum load is 250mA from 5 to 24 VDC source (not included).
- The 7000 can be initiated using a 5 to 24 VDC signal.
- The 7000 can also be initiated with a contact closure such as a mechanical relay or optional foot pedal (order separately #7016714).

Indicator Lamps

In the upper right corner of the front panel are four indicator lamps. These lamps indicate the mode of operation.

POWER - Indicates that there is power to the ValveMate.

RUN - Indicates that the ValveMate is in the RUN mode ready to be initiated through a dispense cycle.

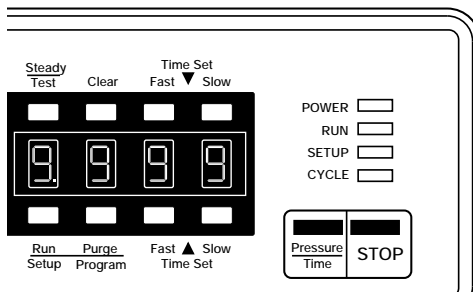

SETUP - Indicates that the 7000 is in the SETUP mode. Time settings can only be changed in this mode.

CYCLE - This lamp is on whenever the control solenoid is open, causing the dispense valve to be open.

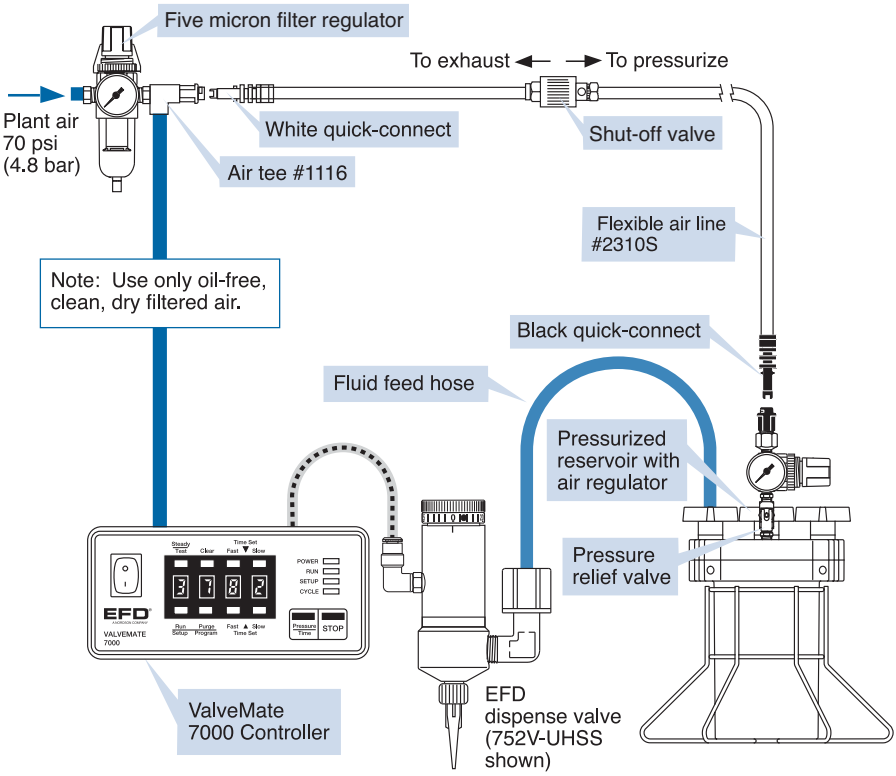

Typical Setup



	Material
	Constant air
	Pulsed air for valve operation

Setup

① Mounting

Included with the 7000 is a universal mounting bracket. Mounting hardware is installed into the four 10-32 mounting holes on the sides of the cabinet. The bracket can be mounted either over or under the cabinet and will allow the 7000 to pivot up or down 30 degrees from a horizontal position. The bracket may be permanently mounted, or attach the rubber feet included and use the bracket as a bench-top tilt stand. Four rubber feet on the console are provided if the bracket is not used.

For panel mounting, a panel mount bracket kit is available (order #7000PMK).

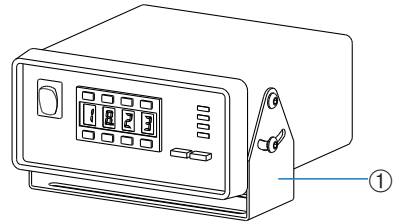

② Input Power

Check the input power cord receptacle fuse cartridge to ensure that the voltage is set properly. The cartridge may be set for input voltages of 100, 120, or 220 VAC.

To change voltage, remove the fuse cartridge. Remove the fuse holder from the cartridge, rotate the holder and position the correct voltage to show through the cartridge window. Replace the cartridge into the power cord receptacle and ensure that both sides snap securely into position.

Install the power cord.

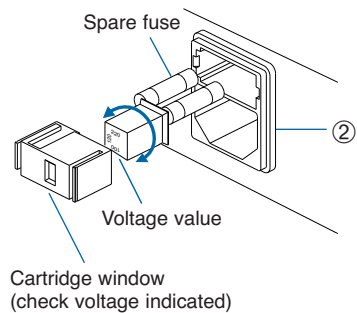

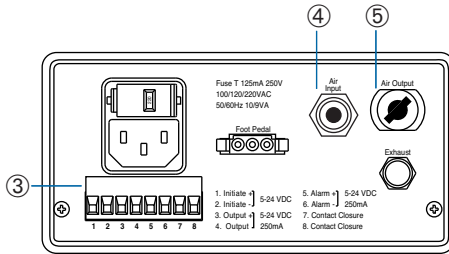

③ Initiate Connection

The 7000 can be initiated through a time cycle by the application of 5 to 24 VDC to terminals 1 and 2, by closure of mechanical contacts across terminals 7 and 8, or by using an optional EFD foot pedal (order #7016714), plugged into the foot pedal receptacle. A connection schematic is detailed on page 15. Select one of these methods and install now.

④ Air Input Connection

Connect the ValveMate 7000 to plant air by first installing the EFD five-micron filter regulator (#7002002) to your air supply.

Install the air tee with barb fitting (#7016230) in the output of the filter regulator.

10 feet of 1/4" OD air line is supplied. Using the barb fitting supplied,

connect one end to the #7016230 air tee. Connect the other end of the air line by pushing it firmly into the air input connector on the ValveMate 7000 until it bottoms out. Be sure that the line is inserted all the way into the fitting.

Set the pressure at the #7002002 filter regulator to 70 psi (4.8 bar).

The quick-connect on the air tee is used to provide air pressure to the air pressure regulator on EFD fluid reservoirs. This connection will be made at a later step in the setup.

⑤ Control Air Output

The dispense valve is connected to this output quick-connect. All EFD dispense valves are equipped with the matching male connector. Insert and twist to lock. At this point, however, do not attach the dispense valve.

Please continue to next page.

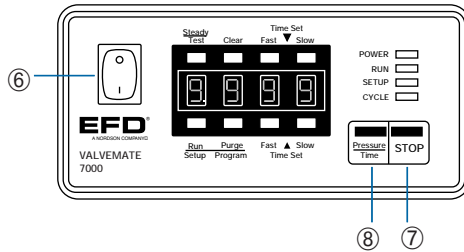

⑥ Turn the Power Switch On.

⑦ Setting the Decimal

The 7000 is shipped with the decimal set at the 99.99 second range.

If the 9.999 second range is desired, change as follows:

To place the display into the time position, press the **PRESSURE / TIME** button. This will toggle the display from pressure to time readout.

To move the decimal, press the **STOP** button and hold it for 3.0 seconds. The decimal point will switch to 0.000. To change back to 00.00, press and hold **STOP** again.

Note: Changing the decimal place will change the current time setting by a factor of 10X. (Example - time setting of 5.350 becomes 53.50.)

⑧ Setting the Pressure Readout

The 7000 is shipped with pressure display programmed in psi.

If bar is desired, change as follows:

Press **RUN / SETUP** and place the 7000 into the **SETUP** mode. Press and hold the **PRESSURE / TIME** button for 3.0 seconds. The display will change from psi to bar. To change back to psi, press and hold **PRESSURE / TIME** for approximately 3.0 seconds.

Installing the Valve

All EFD dispense valves are supplied with a complete instruction manual. If you have not yet read the manual, do this now. The manual will explain the operation of the valve and also how to set up the valve with the fluid reservoir.

FINAL SETUP CHECKLIST

- Fuse cartridge voltage has been checked or adjusted.
- Either voltage or mechanical contact initiate is connected.
- Air pressure of 70 psi (4.8 bar) is connected to the air input fitting.
- Power on.
- Decimal place is set.
- Pressure value is set for psi or bar.

Once you have read the operating manual for the valve that you are using, connected the valve to the fluid reservoir and have the reservoir properly pressurized, you may begin the following steps to install the valve:

1. Install the quick-connect from the air line on the valve to the air output on the back of the 7000. Simply push in and twist to the right to lock.
2. Pressure to the 7000 should be set at 70 psi (4.8 bar). Remember, pressure may be checked by pressing the **PRES-SURE / TIME** button.
3. Place a container under the outlet of the dispense valve.
4. Select and install a dispensing tip on the valve output tip adapter.
5. Place the 7000 into the **RUN** mode and press **PURGE / PROGRAM**. Hold the button until liquid fills the lines and begins to flow from the valve.
6. Continue to purge until the liquid feed lines and valve are free of air.
7. Set up the deposit size using the **TIME SET** buttons illustrated on page 4. Pressing the **TEST** button in the **SETUP** mode will initiate one dispense cycle.

Replacement Parts List

- | | | | |
|-------------|---------------------------------------|--------------|---------------------------------------|
| 1. 7020741 | Display board | 11. 7016641 | Female quick-connect, black |
| 2. 7020763 | Power supply board | 12. 7016689 | Power cord* |
| 3. 7020767 | Fuse drawer | 13. 7016751 | 1/4" OD x .160" ID tubing |
| 4. 7020768 | Air input hose fitting, push-in style | 14. 7016831 | 1/8 NPT x 1/4 barb elbow, low profile |
| 5. 7020769* | Exhaust muffler | 15. 7016832 | 1/8 NPT x 1/4 barb 90°, brass |
| 6. 7020770 | Power switch | 16. 7016835 | 1/8 NPT x 1/4 barb elbow, brass |
| 7. 7020772 | Fuse .125A | 17. 7016514 | Solenoid |
| 8. 7020791 | Transformer | 18. 7016471 | Foot pedal receptacle assembly |
| 9. 7020801 | Pressure sensor | 19. 7002002* | Five micron filter regulator |
| 10. 7020833 | Output circuit fuses | 20. 7016714* | Foot pedal assembly (optional) |

* Not Shown

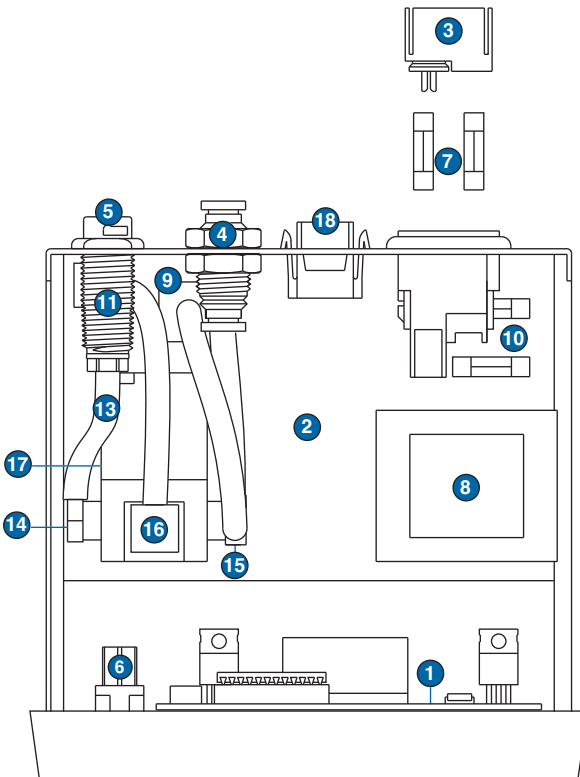

Troubleshooting Guide

Trouble	Possible cause and correction
There is an "AIR" message.	The low level air alarm is active. Raise the input pressure to 70 psi (4.8 bar) on the display. Press RUN / SETUP button to reset.
Unit changes from RUN to SETUP , SETUP light is flashing, and unit has to be reset.	Air pressure has momentarily dropped below 60 psi (4.1 bar). Increase input air pressure to 70 psi (4.8 bar). If already at 70 psi (4.8 bar), check to make sure that other devices such as air cylinders are not causing a pressure drop in the ValveMate 7000 input air line.
No power.	Check the input power fuse. If the fuse has failed, check the voltage value in the fuse cartridge window. Be sure that it matches the input voltage.
End-of-Cycle Feedback Circuit or low pressure alarm is not functioning.	Ensure that the external voltage to the circuit is between 5 and 24 VDC and that the load does not exceed 250mA. If the circuit has been overloaded, the fuse may be open. See internal diagram on page 15 and replace fuse if necessary.
Does not dispense below 0.010 second time setting.	Response delay in pneumatic circuit does not allow the valve to open when time is set at or below 0.010 seconds. Increase time.
Timer is inoperative.	Check to make sure unit is not in STEADY mode. The timer is very reliable. Any failure is total, so no inconsistency is possible.

If trouble cannot be corrected, or if you need further assistance, **please call us**. In the US, call 800-556-3484. In the UK, phone 0800 585733. In Asia, +86 (21) 3866 9166.

Input/Output Connections

1. Voltage Initiate Circuit

The ValveMate 7000 may be initiated with a 5 to 24 VDC signal. The signal can be momentary (no less than 0.008 seconds) or maintained. A new cycle will begin once power is removed and then applied again. Refer to the schematic for proper installation.

2. End-of-Cycle Feedback Circuit

Upon completion of a dispense cycle, an open collector circuit closes and remains closed until the next dispense cycle. This circuit can be utilized to signal back to a host computer, start another device in sequence or other operations that need to be tied into the completion of the dispense cycle.

Upon closure, power from an external source is allowed to pass through the circuit to operate a 5 to 24 VDC load. The load illustrated is a relay, but this could be any device that will operate within the 5 to 24 volt range. Power consumption of the load must not exceed 250mA.

3. Low Pressure Alarm Circuit

The ValveMate features a low pressure alarm output that activates whenever pressure drops below the minimum valve operating pressure of 60 psi (4.1 bar).

Function and circuitry is identical to the feedback circuit described in #2.

See page 4 for deactivate/reactivate procedure.

4. Mechanical Contact Circuit

The ValveMate can be initiated via the closure of mechanical contacts such as a relay or switch. Closure of the contacts can be momentary (no less than 0.008 seconds) or maintained. A new cycle will begin once the contacts are opened and then closed again. Refer to the schematic for proper installation.

Note: For applications using more than one 7000, see pages 16 and 17 for connection instructions.

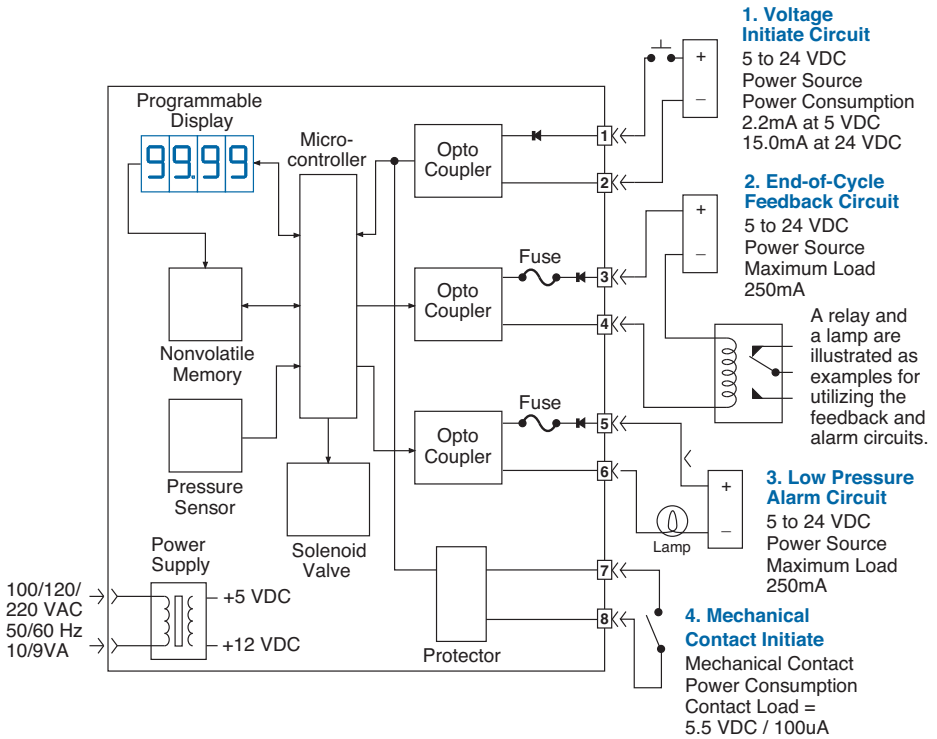

Connecting More than One 7000

Follow these instructions and diagrams when the Voltage Initiate or End-of-Cycle Feedback features are used in a multiple 7000 installation.

1. Voltage Initiate Circuit

To start the dispense cycle for multiple 7000's at the same time, connect the Voltage Initiate Circuit, the Contact Closure Initiate and the Low Pressure Alarm Circuits in parallel as illustrated.

Note: The amperage consumption for the Voltage Initiate Circuit will increase with each ValveMate 7000 that is connected. The initiate power supply should be sized accordingly.

Example: First 7000 consumes 15.0mA at 24 volts. Second one will consume another 15.0mA; now total is 30.0mA. Third one will consume another 15.0 making the total 45.0mA and so on.

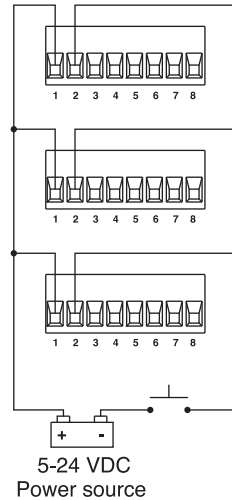

1. Parallel circuit diagram for **Voltage Initiate**. The same diagram should be used when connecting Low Pressure Alarm terminals 5 & 6 or Mechanical Contact Initiate terminals 7 & 8.

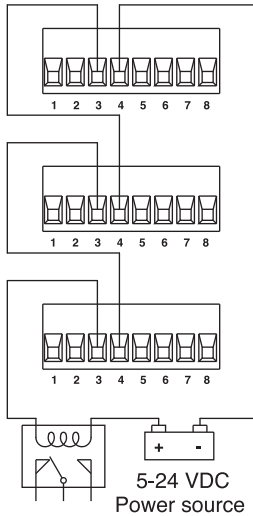

2. Series circuit for End-of-Cycle Feedback feature. A relay is illustrated as one example for utilizing the Feedback Circuit.

REMEMBER: Maximum current through the Feedback Circuit must not exceed 250mA.

2. End-of-cycle Feedback Circuit

This circuit will ensure that the End-of-Cycle will come from the last 7000 to complete a dispense cycle. Connect in series as illustrated.

Note: There will be a maximum voltage drop of 2.0 VDC through the Feedback Circuit with each 7000 that is added to the series. The input power should be adjusted for this drop to ensure that the required voltage is available to operate the load. Maximum input voltage to terminals 3 & 4 must not exceed 30.0 VDC.

Example: The load to be operated through the Feedback Circuit is 12 VDC. Four 7000's are to be used. $4 \times 2.0 = 8.0$ VDC drop. Power supply should provide $(12.0 + 8.0)$ or 20.0 VDC to ensure that 12.0 VDC is available to run the load.

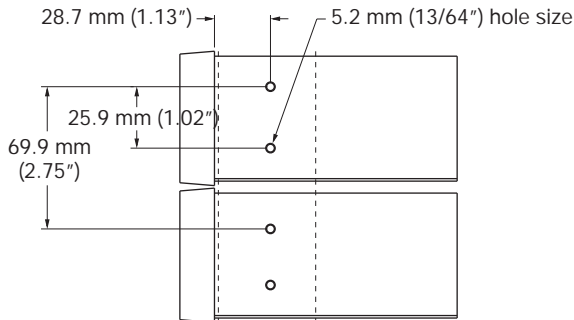

Stack mounting two or more ValveMate 7000's. Use the dimensions in the illustration to make up mounting bracket from flat stock.



**For EFD sales and service in over 30 countries,
contact EFD or go to www.efd-inc.com**

EFD, Inc.

East Providence, RI USA
USA & Canada: 800-556-3484; +1-401-431-7000
info@efd-inc.com www.efd-inc.com

EFD International Inc.

Dunstable, Bedfordshire, UK
0800 585733 or +44 (0) 1582 666334
Ireland 00800 8272 9444
europe@efd-inc.com www.efd-inc.com

EFD, Inc., Asia

China: +86 (21) 3866 9006
china@efd-inc.com www.efd-inc.com/cn
Singapore: +65 6796 9522 sin-mal@efd-inc.com

The Wave Design is a trademark of Nordson Corporation.
©2009 Nordson Corporation 7000-MAN-01 7020492 v070609

To order ValveMate 7000 controller,
refer to part #7020485.



This equipment is regulated by the European Union under WEEE
Directive (2002/96/EC). See www.efd-inc.com for information about
how to properly dispose of this equipment.