

# 725D-SS and 725D Piston Valves

## MAINTENANCE & PARTS GUIDE

---

Electronic pdf files of EFD® manuals are also available at [www.efd-inc.com/manuals.html](http://www.efd-inc.com/manuals.html).

**IMPORTANT!**  
**Save this Sheet.**

**Forward to  
Maintenance or  
Tool Crib  
Supervisors**

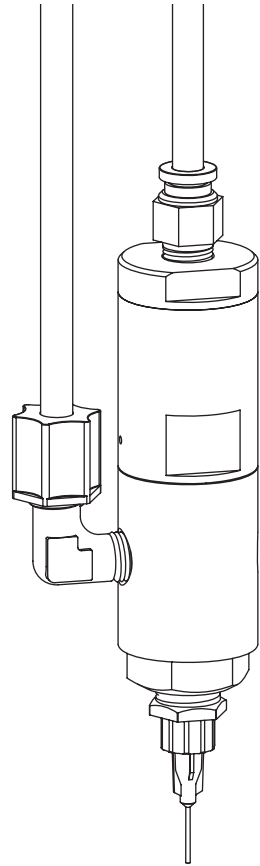

---

**For EFD sales and service in over 30 countries,  
contact EFD or go to [www.efd-inc.com/contact](http://www.efd-inc.com/contact)**

---

**EFD, Inc.**

East Providence, RI USA  
800-556-3484; +1-401-434-1680 (outside the USA)  
[info@efd-inc.com](mailto:info@efd-inc.com)                      [www.efd-inc.com](http://www.efd-inc.com)

**EFD International Inc.**

Dunstable, Bedfordshire, UK  
0800 585733 or +44 (0) 1582 666334  
Ireland 00800 8272 9444  
[europa@efd-inc.com](mailto:europa@efd-inc.com)                      [www.efd-inc.com](http://www.efd-inc.com)

**EFD, Inc., Asia**

China: +86 (21) 5854 2345  
[china@efd-inc.com](mailto:china@efd-inc.com)                      [www.efd-inc.com/cn](http://www.efd-inc.com/cn)  
Singapore: +65 6896 9630    [sin-mal@efd-inc.com](mailto:sin-mal@efd-inc.com)

# Valve Disassembly and Reassembly Procedures

**CAUTION: To prevent damage, the valve must be disassembled starting at the fluid outlet end of the valve.**

1. Put threaded rod in mounting hole.
2. Remove body cap.
3. Remove sealing head.\*
4. With a wrench on the flats of the air cylinder body, turn to loosen fluid body.
5. Remove fluid body.\*
6. Remove input air hose from push-in fitting on air cap.
7. Insert 1/8" hex wrench through air inlet hole in cap and back shaft locking screw out two turns.\*
8. Using the the hex on the shaft, unthread shaft, and remove shaft and diaphragm.\*
9. Unscrew air cylinder cap from air cylinder body.\*
10. Remove piston and spring.  
**Note:** Before reassembling valve, clean all parts, replace O-rings, sealing head and diaphragm. Inspect for damaged threads, piston pins for straightness and fluid body seat for pitting. Reassemble the valve in reverse order of disassembly. Lubricate parts indicated with Nye Lubricant #865 included in the General Maintenance Kit.

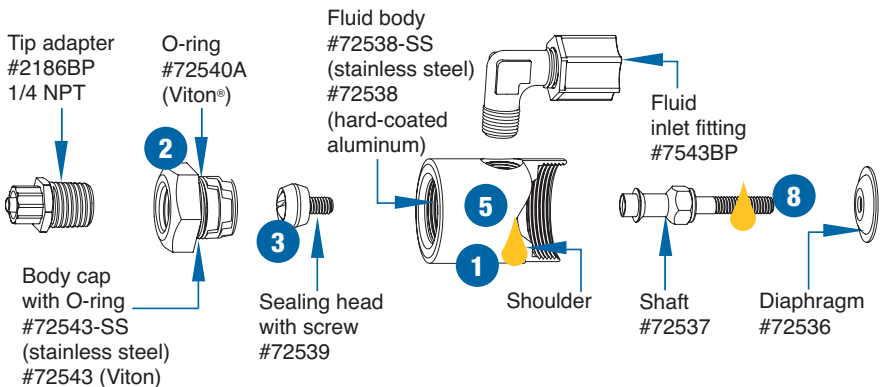



## General Maintenance Kit #725D-RK

Includes air cylinder and body cap O-rings, diaphragm, sealing head with screw and lubricant.

### Maintenance Tools:

- 1/8" hex wrench
- 1/4" flat-tip screwdriver
- 3/8" box wrench
- 7/8" open-end wrench
- 1/8 NPT male pipe or rod

step	part	newton meters	(inch pounds)
3	Sealing head screw	1.69 Nm	(15 inch pounds)
5	Fluid body	6.78 Nm	(5 foot pounds)
7	Shaft locking screw	2.82 Nm	(25 inch pounds)
8	Shaft	1.69 Nm	(15 inch pounds)
9	Air cylinder cap	10.8 Nm	(8 foot pounds)

\* Parts that require a specific torque when reassembling the valve.

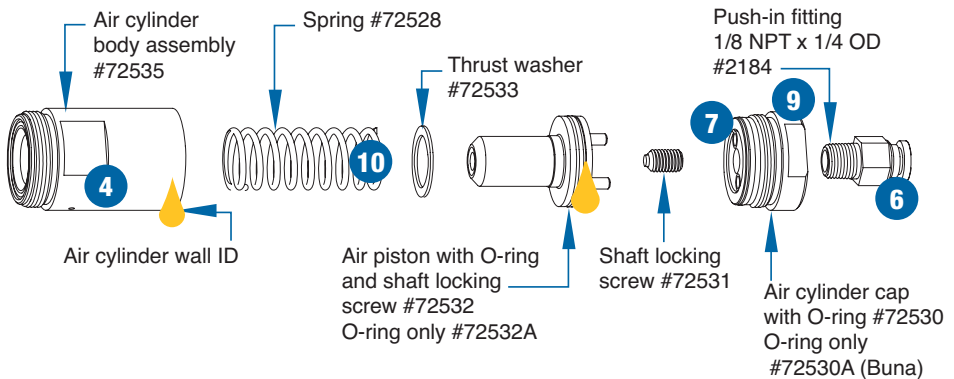

# Troubleshooting Guide

## No fluid flow

- If valve operating air pressure is too low, the valve will not open. Increase air pressure to 70 psi (4.8 bar) minimum.
- The reservoir air pressure may not be high enough. Increase pressure.
- The dispensing tip may be clogged. Replace tip.
- The stroke adjustment may be closed. Open stroke adjustment.
- Fluid may have solidified in the fluid body. Clean the fluid body.
- Fluid supply line is installed in blind mounting hole. Remove and reinstall properly.

## Fluid drools after the valve closes, eventually stopping

- This is caused when air is trapped in the outlet section of the fluid body or the fluid has entrapped air. The air will expand after the valve closes, causing extrusion until the air reaches atmospheric pressure. Purge the valve by dispensing at a steady flow until clear. If a small tip is used, it may be necessary to remove the tip while purging to obtain sufficient flow to carry the air down through the tip adapter.
- If the fluid has entrapped air, the material must be degassed before dispensing.

**Note:** For stripes and lines, input air pressure can be lowered to eliminate opening surge.

## Fluid drips at a steady rate after the valve closes

- A steady drip indicates failure of the sealing head to close fully due to particle buildup or wear. In either

case, replace the sealing head in accordance with the maintenance instructions.

## Valve responds slowly when opening and closing

- Valve response is related to control air hose length and size. The EFD valve is supplied with 5 feet of 1/8" tubing attached. Any additional length or size change will affect response time. Check to be sure the length and size have not been changed.

## Fluid flows out of the drain hole

- Fluid flowing out of the drain hole indicates a ruptured diaphragm. Replace in accordance with the maintenance instructions.

## Inconsistent deposits

- Inconsistent deposits can result if the air pressure controlling the valve and/or supplying the reservoir is fluctuating or if the valve operating pressure is less than 70 psi (4.8 bar). Check to be sure air pressures are constant and the valve operating pressure is 70 psi (4.8 bar).
- The time the valve is open must be constant. Check to be sure the valve controller is providing a consistent output.



USA: 800-556-3484 or +1-401-434-1680  
Europe: 0800 585733 or +44 (0) 1582 666334  
Asia: +86 (21) 5854 2345  
technical@efd-inc.com      www.efd-inc.com