

# 750V, 750V-SS and 751V Dispense Valves **MAINTENANCE & PARTS GUIDE**

---

Electronic pdf files of EFD® manuals are also available at  
[www.efd-inc.com/manuals.html](http://www.efd-inc.com/manuals.html).

**IMPORTANT!**  
**Save this Sheet.**

**Forward to  
Maintenance or  
Tool Crib  
Supervisors**



**For EFD sales and service in over 30 countries,  
contact EFD or go to [www.efd-inc.com/contact](http://www.efd-inc.com/contact)**

---

**EFD, Inc.**

East Providence, RI USA  
800-556-3484; +1-401-434-1680 (outside the USA)  
[info@efd-inc.com](mailto:info@efd-inc.com)                      [www.efd-inc.com](http://www.efd-inc.com)

**EFD International Inc.**

Dunstable, Bedfordshire, UK  
0800 585733 or +44 (0) 1582 666334  
Ireland 00800 8272 9444  
[europa@efd-inc.com](mailto:europa@efd-inc.com)                      [www.efd-inc.com](http://www.efd-inc.com)

**EFD, Inc., Asia**

China: +86 (21) 5854 2345  
[china@efd-inc.com](mailto:china@efd-inc.com)                      [www.efd-inc.com/cn](http://www.efd-inc.com/cn)  
Singapore: +65 6896 9630    [sin-mal@efd-inc.com](mailto:sin-mal@efd-inc.com)

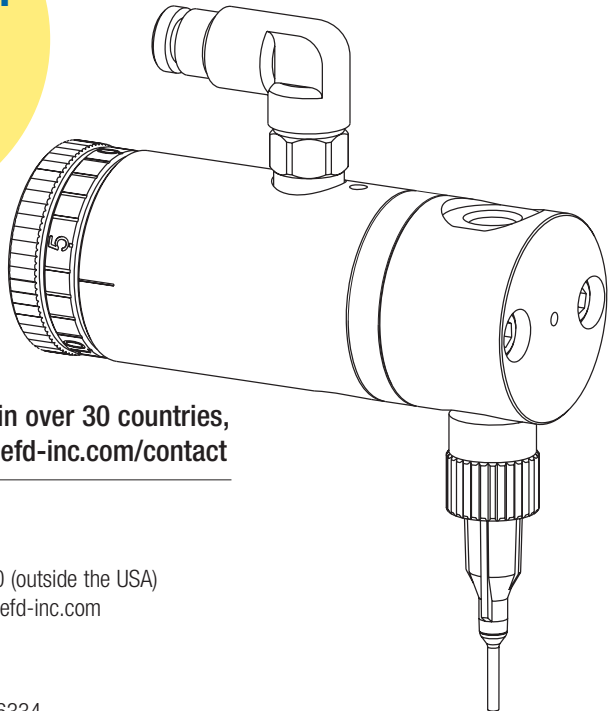

# Valve Disassembly and Reassembly Procedures

**CAUTION:** To prevent damage, the valve must be disassembled starting at the fluid outlet end of the valve.

## Fluid Body

1. Remove the two retainer screws.
2. To reinstall the fluid body, align fluid body holes with diaphragm and air cylinder body holes and reinsert retainer screws. Tighten in accordance with the following torque specifications:

Fluid body	newton meters	(inch pounds)
Acetal (black)	1.58 Nm	(14 inch pounds)
UHMW* (yellow)	0.79 Nm	(7 inch pounds)
Stainless steel	1.58 Nm	(14 inch pounds)

\*Ultra High Molecular Weight

## Diaphragm

3. Back-out stroke control knob two turns counterclockwise from the closed position.
4. Remove fluid body.
5. Unscrew diaphragm (counterclockwise) and remove it from the piston rod.
6. Thread-on the new diaphragm and tighten with medium pressure.
7. Align the holes of the diaphragm with the appropriate holes in the air cylinder body by inserting a flat tip screwdriver through the hole in the stroke control knob and engage piston rod slot.
8. Rotate rod, piston and diaphragm assembly clockwise until holes are aligned.
9. Reinstall fluid body.
10. Turn stroke control knob clockwise until closed, and then reopen to approximate stroke.

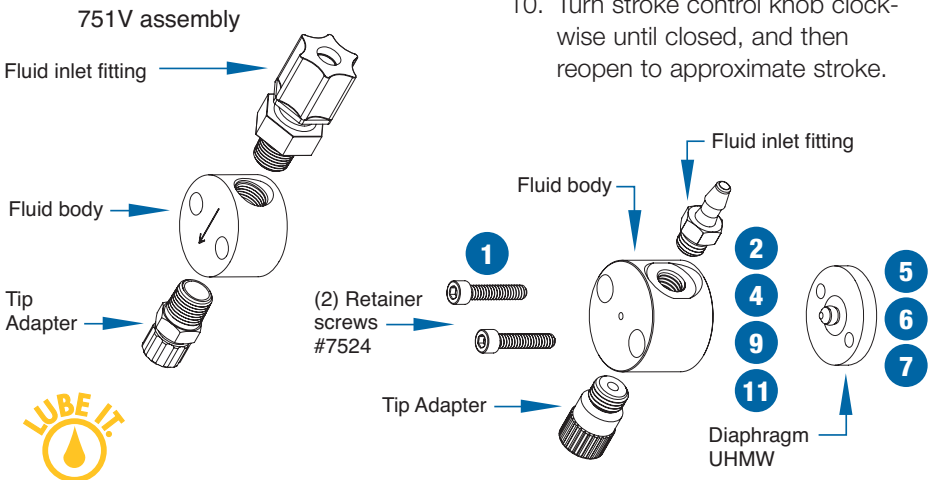

## Piston O-ring

- Remove fluid body and diaphragm.
- Remove stroke control knob and spring by turning counterclockwise.
- Remove the piston retainer ring and anti-torque washer.
- Remove the piston.
- Lubricate O-ring, piston shaft and air cylinder wall with Nye Lubricant #865.
- Reinstall components in reverse order of disassembly.

### Tools required:

- 7/64" hex wrench
- 1/8" flat-tip screwdriver
- 6" adjustable wrench
- 6" needle-nose pliers
- snap-ring pliers

## Replacement Parts for Specific Valve Models

Model	Fluid Body			Fluid Inlet Fitting	Tip Adapter	Diaphragm
	UHMW	Acetal	Stainless*			
750V & 750V-SS	7521	n/a	7521-SS*	7511BP (1/8" ID Tube)	7514	7510
751V	n/a	7521D	7521D-SS	7611BP (1/4" OD Tube) 7610BP (3/8" OD Tube)	7514B	7510

\*optional

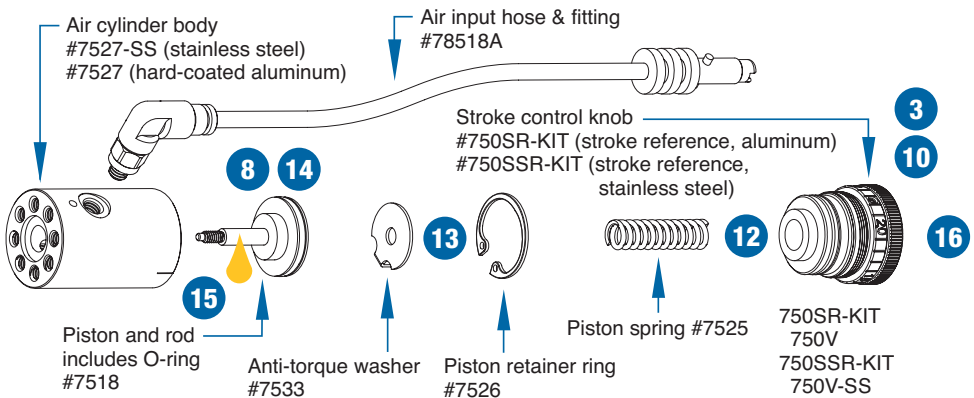

# Troubleshooting Guide

## No fluid flow

- If valve operating air pressure is too low, the valve will not open. Increase air pressure to 70 psi (4.8 bar) minimum.
- The reservoir air pressure may not be high enough. Increase pressure.
- The dispensing tip may be clogged. Replace tip.
- The stroke adjustment may be closed. Open stroke adjustment.
- Fluid may have solidified in the valve. Clean the fluid body.

## Fluid drools after the valve closes, eventually stopping

- This is caused when air is trapped in the outlet section of the fluid chamber or the fluid has entrapped air. The air will expand after the valve closes, causing extrusion until the air reaches atmospheric pressure. Purge the valve by dispensing at a steady flow until clear. If a small tip is used, it may be necessary to remove the tip while purging to obtain sufficient flow to carry the air down through the tip adapter.
- If the fluid has entrapped air, the material must be degassed before dispensing.

## Fluid drips at a steady rate after the valve closes

- A steady drip can be caused by excessive reservoir pressure. Check to be sure the reservoir pressure is not above 70 psi (4.8 bar).
- If the stroke adjustment knob is turned-out more than two full turns, resulting in reservoir pressure that will force the diaphragm open. Check the stroke adjustment knob to be sure it is less than two turns out.
- A steady drip also indicates failure of the diaphragm to close fully due to particle build-up or wear. In either case, replace the sealing head in accordance with the maintenance instructions.

## Fluid leaks out between fluid body and diaphragm

- Fluid leakage between the fluid body and diaphragm indicates the annular sealing ridge on the fluid body is damaged or the fluid body is distorted due to excessive torque on the retaining screws. In either case, replace the fluid body.

## Fluid flows out of the drain hole

- Fluid flowing out of the drain hole indicates a ruptured diaphragm. Replace in accordance with the maintenance instructions.

## Valve responds slowly when opening and closing

- Valve response is related to control air hose length and size. The valve is supplied with 5-feet of 3/32" ID tubing attached. Any additional length or size change will affect response time. Check to be sure the length and size have not been changed.

## Inconsistent deposits

- Inconsistent deposits can result if the air pressure controlling the valve and/or supplying the reservoir is fluctuating or if the valve operating pressure is less than 70 psi (4.8 bar). Check to be sure air pressures are constant and the valve operating pressure is 70 psi (4.8 bar).
- The time the valve is open must be constant. Check to be sure the valve controller is providing a consistent output.



USA: 800-556-3484 or +1-401-434-1680  
Europe: 800 585733 or +44 (0) 1582 666334  
Asia: +86 (21) 5854 2345  
technical@efd-inc.com      www.efd-inc.com